



MicroTester G2

Micro-scale Tension-Compression Test System

User Manual
version 5.5



Mechanical measurement and analysis of biomedical materials

CellScale provides scientific and medical researchers with turn-key systems for measuring the mechanical properties of biomaterials.

Our focus is soft tissue – including skin, ligaments, blood vessels, heart valves, sclera, membranes, and scaffolds. We provide user-friendly software, easy-to-use patented attachment systems, and effective data analysis tools.

Our foundation was laid at one of the world's leading research institutions – the University of Waterloo. We understand research and aim to provide effective solutions at a reasonable price.

Explore our web site www.cellscale.com or contact us to learn more about our measurement systems.

© 2026 CellScale. All rights reserved. This material may not be reproduced, displayed, modified or distributed without the express prior written permission of the copyright holder. For permission, contact CellScale Biomaterials Testing at info@cellscale.com.



Sales and Support
CellScale Biomaterials Testing
564 Weber St N, Unit 5, Waterloo, Ontario
Canada N2L 5C6
Phone: 519.342.6870

Table of Contents

1. General Information	1
System Assembly	1
Connections to Supply	1
Safety Warnings.....	1
Operating Controls.....	1
General Maintenance.....	1
Approvals and Certification	2
2. Parts	3
Tools	3
Basic Components.....	3
3. Testing Terminology.....	4
Multiphase Test Cycles.....	4
Phases, Cycles, and Test Sequences	5
Test Phases: The Smallest Unit of Testing.....	6
Control Modes.....	7
Control Functions.....	7
4. System Overview	8
Microbeam	8
Microbeam Actuators	10
Imaging System	10
Fluid Bath.....	10
Software Overview	12
Output Files and Data Structures	13
5. Setting Up & Starting a Test.....	14
Overview	14
Step 1: Start a New Test.....	15
Step 2: Modify Testing Parameters (optional)	16
Step 3: Specify the Microbeam Properties (Occasional)	19
Step 4: Load the Specimen.....	20
Step 5: Set the Optics Zoom Level	21
Step 6: Adjust the Initial Size Crosshairs	21
Step 7: Select a Tracking Point	22
Step 8: Execute the Test.....	23
Step 9: Terminate the Test Prematurely (optional).....	23
6. Additional Settings	24
Camera Shutter and Gain	24
Grid Overlay	24
Temperature	25

Configuring the Real-Time Graphs	26
Data Output Settings.....	27
Advanced Settings	28
7. Reviewing Test Results.....	30
8. System Calibration and Advanced Tools	31
Piezo Calibration	31
Optics Calibration.....	32
Snap Image.....	33
Beam Calibration	34
9. Mounting a MicroBeam	35
10. Force Calculation Formulas	42
11. Appendix A: System Setup	43
Unpack Main Unit, Controllers, and Accessories	43
Foam Removal from Piezo Stack	44
Attach Spacer to Vertical Piezo Stage	45
Camera Unpacking and Assembly	46
Remove Lens Cap and Mount the Ring Light on the Lens Assembly	53
Set Test Chamber on the Chamber Holder	54
Place Temperature Sensor in the Test Chamber	54
Connect Cables	55
System Calibration Check.....	56
12. Appendix B: Software Installation	57
Update Firmware	61
13. Appendix C: Shear Testing	63
Installing the Shear Axis Keyence Sensor	64
14. Appendix D: Camera Lens Attachment.....	69
15. Appendix E: Attaching Secondary Camera.....	74
16. Appendix F: Software Troubleshooting.....	80
17. Appendix G: Accessories	81
Tension Forks	81
3-Point Bend	84
Spherical Indentation	86

1. General Information

Electrical Output from Power Supply	24 VDC
Output Current Rating of Power Supply	2.71 Amp
Recommended Computer OS	Windows 10
Environmental Conditions	Maximum Operating Temperature 25°C 20% - 80% Relative Humidity
Installation Category	Category II
Pollution Degree	Degree II
Data Connections	1 – USB 3.0 (SS) for camera/PC communication 1 – USB for Main system/PC communication USB hubs may be used for computers that have insufficient ports, as long as the hub supports and provides USB 3.0 connections.

System Assembly

Please see instructions in Appendix A for details on system assembly. See Appendix B for installing the software, and Appendix C for details on setting up the host computer.

Connections to Supply

Connect power cords to properly grounded 100-240VAC power source to ensure safe operation. Ensure that the power cords are always easily accessible. The use of an Uninterruptible Power Supply (UPS) is recommended to protect against data loss.

Safety Warnings

This equipment must be used in accordance with the procedures outlined in this manual to prevent injury and/or damage.

Operating Controls

There are no manual controls on the MicroTester G2 main unit. Both the camera and microbeam assembly contains motorized X, Y and Z adjustment stages to position and focus the camera view. In addition, the camera brightness can be controlled by setting the software interface.

General Maintenance

Clean the system as needed with mild soap and water or alcohol-based cleaning solutions.

Approvals and Certification

We declare that the CellScale MicroTester G2 complies with the requirements of the Electromagnetic Compatibility Directive, 2004/108/EC by demonstrating compliance with the following standards to the extent applicable:

EN 55011: 2008 Class A

EN 61000-3-3: 2008

EN 61000-4-2: 2009

EN 61000-4-3: 2006 (+A1:2008 +A2:2010)

EN 61000-4-4: 2005 (+A1: 2010)

EN 61000-4-5: 2006

EN 61000-4-6: 2009

EN 61000-4-8: 2010

EN 61000-4-11: 2004

2. Parts

Tools

Small flat head screwdriver

SAE hex wrenches: 5/64", 3/32"

Metric hex wrenches: 1.5mm, 2mm, 2.5mm, 3mm

Rectangular flat wrench

Basic Components

Main Assembly

Piezo Stage Controller

Position Sensor Controller (with LED power supply)

USB 3.0 Colour Camera

Motorized XYZ Camera stages and Controller

3. Testing Terminology

The MicroTester G2 is designed to apply compressive loads to small test specimens 50 to 2000 μm in size. Typical specimens include biological tissue samples, scaffolds, cell aggregates, or hydrogel microspheres.

Multiphase Test Cycles

In order to properly characterize and test a specimen, it is often necessary to load it to different degrees and at different rates. There are three main reasons for doing this:

Preconditioning - The goal of preconditioning is to restore a specimen to its physiological or *in vivo* state. During the process of specimen storage and preparation, a specimen may swell, dry out, have its material fibers realign, or its molecules reorganize. It may take multiple preconditioning cycles for a specimen to be restored to its natural state.

Reproducing Physiological Conditions During Testing - By applying various loads and load rates, natural expansion and contraction of a specimen can be reproduced (for example, the pulse pressure in an organ). In as much as the physiological conditions can be recreated, the specimen can be tested in a more realistic state.

Varying Test Conditions - Variable loads and rates allow you to create a variety of test profiles to best study your specimen.

Phases, Cycles, and Test Sequences

As the following diagram demonstrates, each application and release of load on the specimen is called a **test cycle**. The same test cycle can be repeated multiple times to achieve a certain goal (preconditioning, physiological conditioning, or testing); this is called a **test set**. Finally, a **test sequence** is made up of multiple test sets.

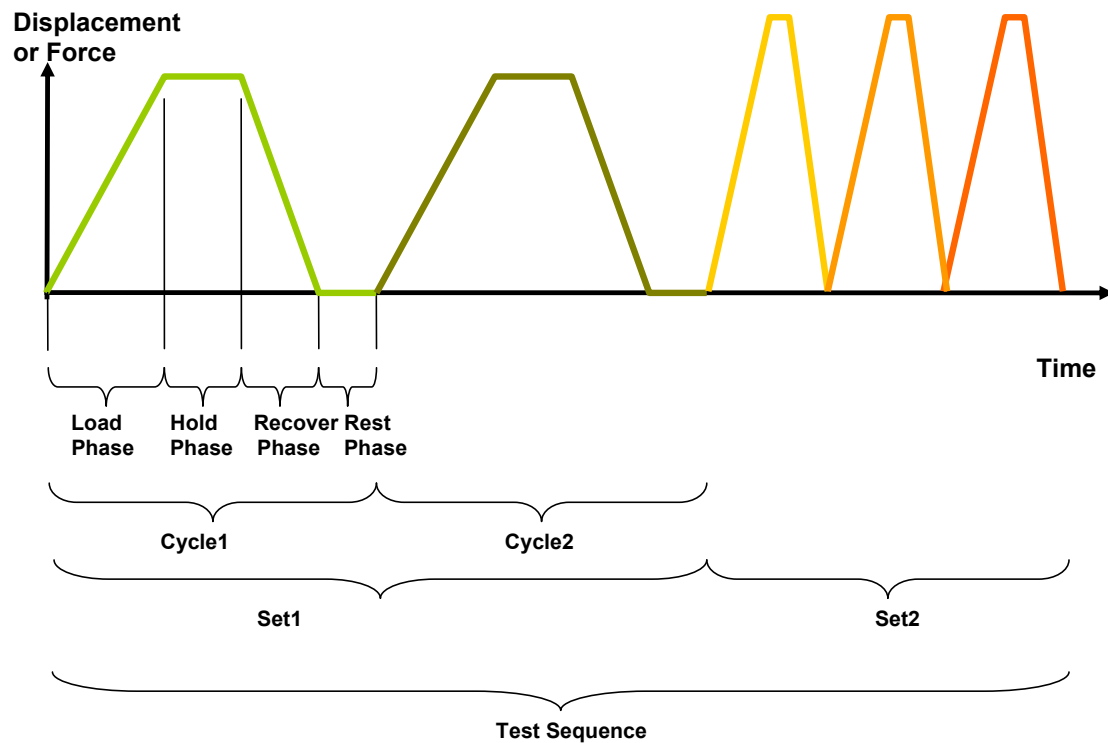

The above example describes the following:

- The entire diagram presents a full *test sequence*.
- Within that sequence, there are two *test sets*.
- Within the first set, two identical *test cycles* are implemented to bring the sample to a satisfactory in vivo state.
- Finally, the second set is made up of three cycles.

Test Phases: The Smallest Unit of Testing

The test phase is the smallest unit of the test specification. There are four phases within a cycle. Each phase serves a specific purpose:

Loading - During the load phase, a deformation is applied to the specimen. The deformation can be specified either in terms of force applied or displacement achieved.

Holding - The deformation can be held for a given duration. The duration for which it is held is dependent on the nature of the testing.

Recovering - The recovery phase is the time during which the force being applied to the specimen is removed. The duration of the recovery time is configurable and dependent on the nature of the testing.

Resting - Finally, the rest phase is the time between the end of one cycle and the beginning of the next. Some tests may specify a short recover time, while others may specify a longer time. The duration is configurable and dependent on the nature of the testing.

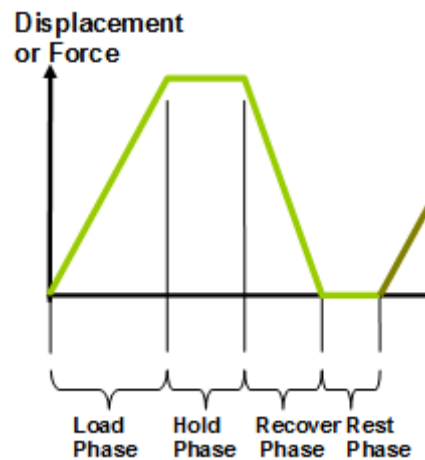

Control Modes

There are two control modes which define the basic approach to a given test: displacement control and force control:

Under **displacement control**, the displacement of the specimen is predefined. The MicroTester G2 compresses the specimen until the predefined displacement is achieved. The force required to achieve the displacement is an output of the test.

Under **force control**, the force applied to the specimen is predefined. The MicroTester G2 compresses the specimen until the predefined force is achieved. The displacement required to achieve the force is an output of the test.

Control Functions

The MicroTester G2 makes it possible to test specimens under several control functions with Displacement or Force control modes:

The **ramp function** applies the displacement at a constant nominal rate. This is equivalent to a constant engineering or nominal strain rate.

The **step function** achieves and maintains the desired force as quickly as possible. The amount of time it takes to achieve the desired force depends on the material being tested and the control settings.

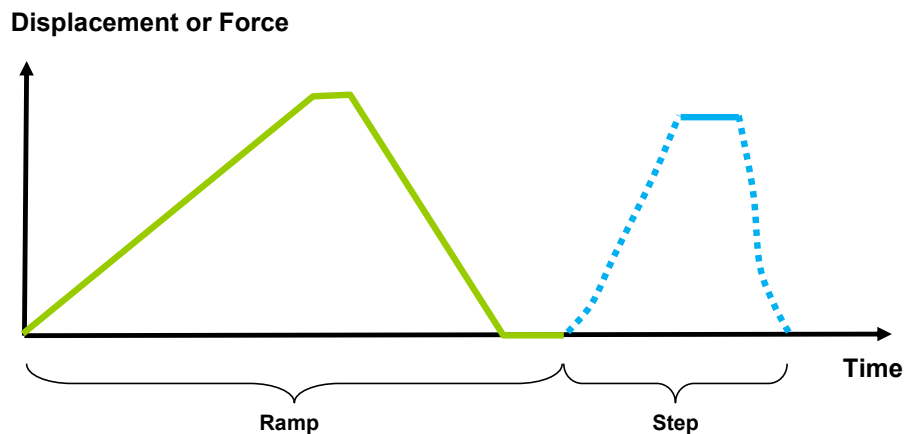

4. System Overview

The MicroTester G2 is a mechanical test device that can be used to test the properties of a variety of tissues and materials.

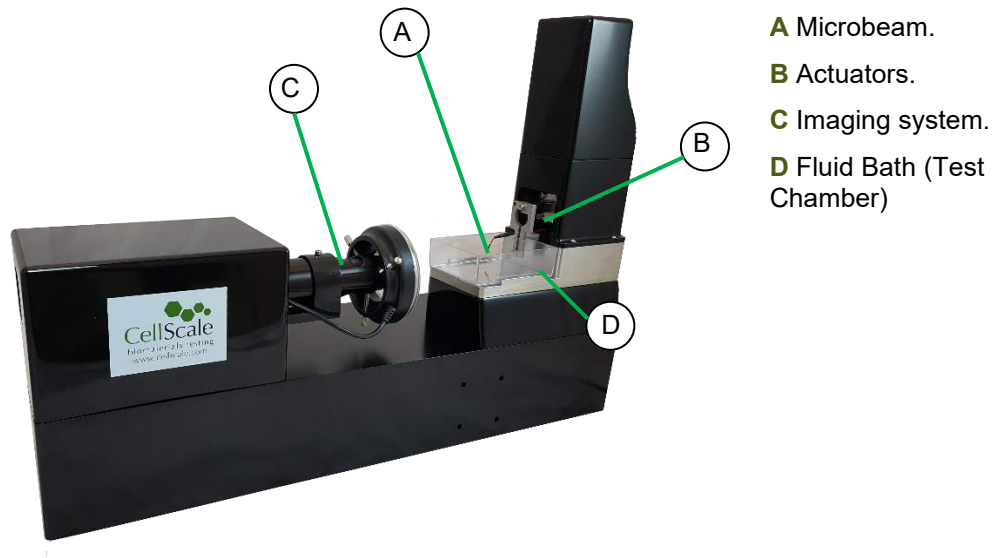

The main components of the device are the load application microbeam, the actuators, the imaging system, and the fluid bath/test chamber.

Microbeam

The microbeam is rigidly fixed to the vertical actuator (which is under closed loop control). It has a flexible shaft that is typically between 30mm and 50mm long and can be made from a length of metal, glass, or plastic with a circular or rectangular cross section. Circular tungsten beams are supplied with the system. At the end of the shaft is a rigidly fixed compression plate. This plate is typically made from a small square of micro-cut stainless steel and is adhered to the end of the shaft. Cyanoacrylate and adhesive accelerator are provided for this purpose.

The microbeam is used to apply deformations to the test specimen while measuring the applied forces. The deformation is determined by measuring the difference between the current tip position and the initial tip position. These measurements are obtained in real time at a frequency of 5 Hz by image tracking techniques. The applied force is determined by calculating the deflection of the microbeam (the difference between the displacement of the tip and the displacement of the actuator). The displacement of the actuator is obtained directly from a position feedback device (displacement sensor) mounted to the actuator.

Because the microbeam is used for 2 purposes (apply deformation and measure forces), an iterative control scheme is necessary to achieve the desired result. For example, if a tip displacement of 100 μ m is desired, it is unknown at the start of the test how much actuator travel will be required to move the tip by this amount since some of the stage travel will result in tip displacement and some will result in microbeam bending.

The microbeam can have a variety of constructions and must be tailored to the force ranges that are to be measured. If the microbeam is too stiff, then the beam deflection will be too small. This has a negative influence on the force resolution. This is a result of the position resolution of the base and tip displacement measurements, which are both approximately 0.1µm. For example, if the microbeam only deflects 2 µm during the test, then the force resolution is only 1/20 of the maximum force.

Conversely, if the microbeam is too flexible, then the deflection will be too large. This can have a negative influence on the reaction time of the device and on the parallelism of the compression plates. With more deflection of the microbeam, the actuator must travel further to achieve the desired tip displacement. Since the velocity of the actuator is limited to about 2mm/s, this can cause unwanted delays. Also, as the beam deflects, the top compression plate can become slightly less parallel to the lower compression plate. In a test with a moderate microbeam deflection of 100µm, this effect is very small, since the beam is typically over 30mm long. In a test with a large microbeam deflection of 2mm, this effect becomes more significant.

The table below shows a list of the microbeams that come with the MicroTester G2 system and the appropriate maximum forces for each diameter. A chapter containing details of the force calculations can be found later in this manual.



Diameter (mm)	0.0762	0.1016	0.1524	0.2032	0.3048	0.4064	0.5588
Modulus (MPa)	411000	411000	411000	411000	411000	411000	411000
Typical Force Resolution (µN)	0.012	0.038	0.191	0.604	3.056	9.658	34.52
Recommended Max Force (µN)	4	11	57	181	917	2,897	10,536

Microbeam Actuators

There are 2 actuation systems integrated to the microbeam assembly. The first system is comprised of the 2 piezo motor driven actuators that are used to position the microbeam in plane before the start of the test. The actuators are controlled by the user, using on-screen controls in an open loop jog mode. There is no absolute measurement of how far they have been moved since feedback is based on user interpretation of the live on-screen image.

The second actuator system is the closed-loop, piezo motor actuator that is used to move the microbeam vertically. It is driven in a user-controlled jog mode during setup and then under computer control during the test (specially modified systems are also available to track horizontal displacement as well, in which case the horizontal actuator is also under closed loop control). The actuator used for this purpose is identical to the other 2 axes, but the system also incorporates a position feedback device. This displacement sensor has 0.1um resolution and allows for the software to determine the displacement of the actuator relative to the start of the test. This motion constitutes the movement of the base of the microbeam. The displacement of the base and tip of the microbeam are needed in order to determine the deflection of (and hence the force applied by) the microbeam.

Imaging System

The imaging system is comprised of a USB digital camera, a zoom lens, and a motorized XYZ stage assembly to allow position adjustment and focusing. The camera has a resolution of 2048 X 2048 pixels and can match the control frequency of 5Hz. The zoom optics allow for a field of view ranging from approximately 0.4mm to 12.0mm.

The imaging system comes with interchangeable tubes and auxiliary zoom lenses for 1X and 2X magnification. How to change between lenses can be found in Appendix E.

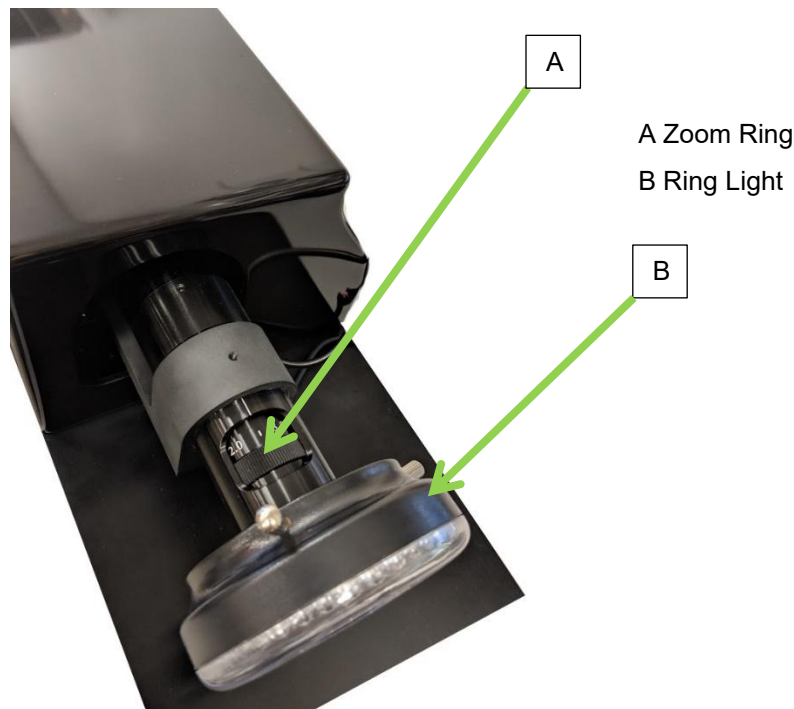

Fluid Bath

The fluid bath contains approximately 45mL of fluid and is heated by a resistance foil heater in the base of the bath. The fluid temperature is controlled by an onboard temperature controller that communicates with the PC via the USB connection. The temperature of the bath is measured by a solid-state temperature probe with a temperature resolution of 0.1°C. To function the MicroTester G2 software will log the actual temperature of the fluid. To enable the controller to heat the fluid, the “HEATER” switch beside the main power switch must be turned on to illuminate the amber heater light.

MicroTester G2 Tip: Temperature Probe

*The temperature controller works best if the temperature probe tip is completely submerged and **not** touching the side of the fluid chamber.*

The bath is a clear polycarbonate dish which allows for visibility from all sides, the main imaging system is setup to image the front side of the dish, where the compression platform is setup in the image below. The compression plate is typically made of a stainless-steel block and is flush with the front window.

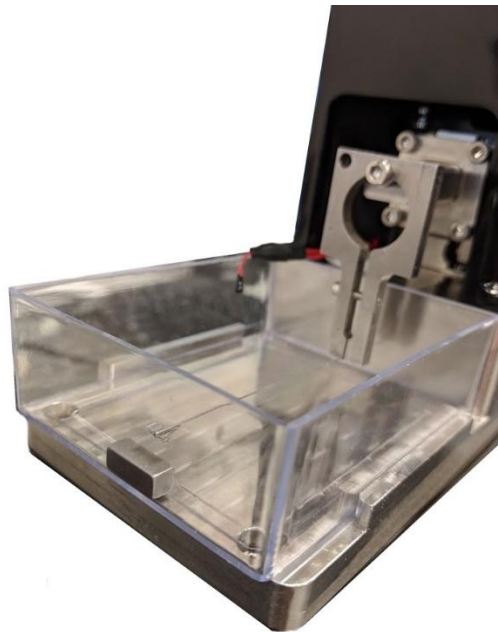

Software Overview

The software included with the MicroTester G2 system is called MicroTester G2. It is divided into two modules: a data collection module and a review and analysis module. The data collection module is used to set test parameters, enable specimen loading and testing, and monitor test progress. The screen layout for this module is shown below:

Test Parameters

Live Output

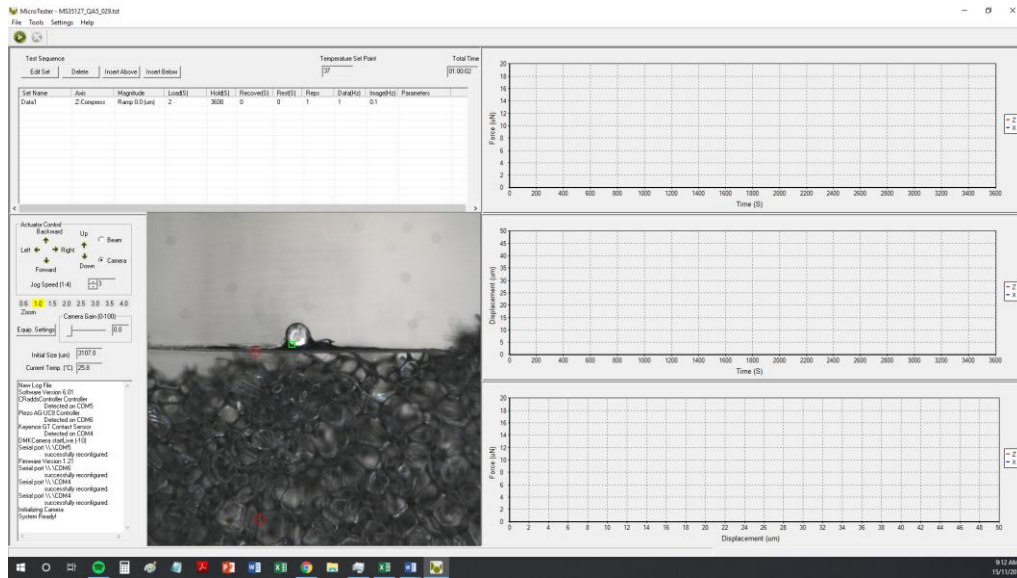

Live Video

Live Graphs

Output Files and Data Structures

For each test, the MicroTester G2 creates and saves three file types. The following table describes the five file types for a project named “Sample1”. Output from this test would be found in a “Sample1” output directory (a sub directory of the user specified data directory).

File Type	Description
.tst file	The Sample1.tst file that contains the exact protocol and settings used for the test.
.csv file	The Sample1Data.csv file that contains comma separated numerical data such as time, force and displacement values.
.jpg files	Captured images such as Sample1.0001000.jpg, which would correspond to an image captured at 1000 milliseconds from the start of the test.

Each test folder will also contain 2 subfolders. The “Logs” subfolder contains a text file of the content of the text dialog portion of the main screen. It is useful as reference to troubleshoot problems with your system, should they occur.

The “Tracking” subfolder is initially empty. If tracking is done on any of the images in the test folder using the “Analyze and Review” software module, there will be data files that contain the tracking information stored in this directory.

While using the “Analyze and Review” software module, you may create additional data files such as text files (*.csv) containing tracking results, images with force data or tracking results overlaid (*.wmf), or movie files (*.avi). These additional files can be stored in the test directory or elsewhere on your computer’s hard drive without interfering with the software application (once created, they cannot be opened by the MicroTester G2 application).

5. Setting Up & Starting a Test

Overview

Setting up and running a new test is a simple process made up of both mandatory and optional steps. The following list presents all the steps, while the rest of this chapter describes each of the steps in detail.

Step 1: Start a New Test

Step 2: Modify the Test Parameters (optional)

Step 3: Specify the Microbeam properties (occasional)

Step 4: Load the Specimen

Step 5: Set the Optics Zoom Level

Step 6: Adjust the Initial Size Crosshairs

Step 7: Select a Tracking Point

Step 8: Execute the Test

Step 9: Terminate the Test Prematurely (optional)

Step 1: Start a New Test

Launch the MicroTester G2 software, and then select Collect New from the File menu. In the Create Test From Template dialog, perform the following steps:

1. Select a template that matches the type of test you wish to perform. See the *MicroTester G2 Tip* on how to select and use a template. You can modify the template parameters in Step 2, below.
2. Name your test. The dialog will have a default test name. You can use the default or rename the test. Each time you start a new test, the default name will continue to increment the number at the end of the name.
3. If desired, you can change the location of the output data. The location of your output data and images is determined by specifying a Test Name and Data Directory. The template and data directories are user specific (computer login name). Each system user can store their files to a different default location. The system uses the last location selected as the default.

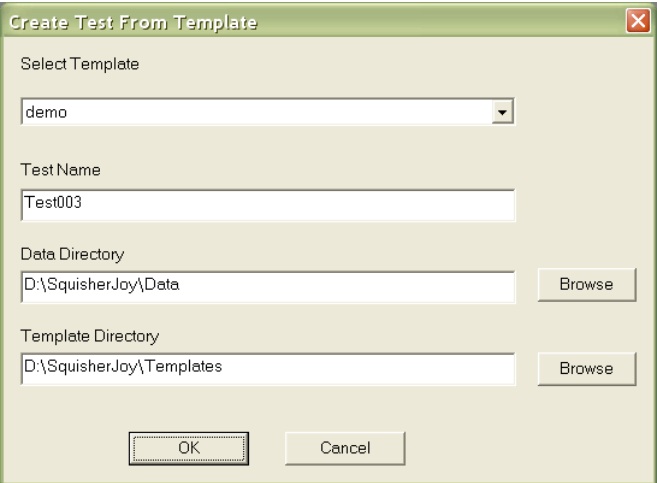

The screenshot shows the 'Create Test From Template' dialog box. It has a title bar with a close button. The dialog contains the following fields and controls:

- Select Template:** A dropdown menu with 'demo' selected.
- Test Name:** A text box containing 'Test003'.
- Data Directory:** A text box containing 'D:\SquisherJoy\Data' and a 'Browse' button to the right.
- Template Directory:** A text box containing 'D:\SquisherJoy\Templates' and a 'Browse' button to the right.
- Buttons:** 'OK' and 'Cancel' buttons at the bottom center.

MicroTester G2 Tip: Selecting and Using Templates

How to select a template: Designing an appropriate test sequence is an art that depends on both the type of material being tested and the specific material properties you are interested in measuring. When first testing a new material, you should expect to have to experiment with the settings until the test yields meaningful data.

The system comes loaded with example templates to help you get started. Selecting a template does not lock you into a specific test sequence or protocol – rather a template defines a test sequence and settings, all of which can be changed before a test is run. Once you have developed a test sequence and settings that are appropriate for the material you are testing, you should save these settings using “Save As Template” from the file menu. You can then select your template the next time you initiate a test.

Step 2: Modify Testing Parameters (optional)

You can select and modify test parameter sets by clicking on their row in the Test Sequence table and then pressing the Edit Set button (or by double clicking on their row).

Test Sequence											Temperature Set Point	Total Time
<input type="button" value="Edit Set"/> <input type="button" value="Delete"/> <input type="button" value="Insert Above"/> <input type="button" value="Insert Below"/>											37	00:00:45
Set Name	Axis	Magnitude	Load(S)	Hold(S)	Recover(S)	Rest(S)	Reps	Data(Hz)	Image(Hz)	Parameters		
Data1	Z-Compress	Ramp 200.0 (um)	20	5	20	0	1	5	1			

When you do so, the Set Parameter Editor Dialog will appear.

Note that displacements are specified in either % strain, or μm . Force loads are specified in μN , and durations are specified in seconds.

The following table describes each of the parameters.

Set Parameter Editor
×

Name (Example: "Squish1", "TestData1")

Axis

Control Axis

Control Mode

Control Function

Compress Magnitude

Tolerance (um)

Correct Overshoot

Cycle

Loading Duration (S) Do Not Load

Repetitions

Hold Duration (S)

Data Output Frequency (Hz)

Recovery Duration (S) Do Not Recover

Image Output Frequency (Hz)

Rest Duration

Test Parameter	Description
Control Axis	Loading is normally applied in the vertical Z-Compress axis. MicroTester G2 systems that have been equipped with a second displacement control axis can also apply horizontal shear loads by selecting the X-Shear axis.
Control Mode	Compression tests are typically performed under displacement control. However, you can select the following control modes to achieve specific testing objectives: <ul style="list-style-type: none"> • For creep testing, use force control with a long hold duration. • For relaxation testing, use displacement control with a long hold duration.
Control Function	Ramp functions are most commonly used although step functions are also used.
Compress Magnitude (Load Magnitude when in Force Control mode)	Compression magnitude is specified as an absolute position or force relative to the initial state of the microbeam. Positive magnitudes are compressive (the beam moves down). In systems equipped to perform horizontal shear testing, positive magnitudes are to the right. If you are using Displacement control mode, you can specify the displacement in either μm or as a percentage. For example, the displacement on a $1000\mu\text{m}$ Initial Size specimen can be expressed as either $100\mu\text{m}$ or 10%. If you are using Force control mode, you can only specify the force magnitude in μN . Watch the test results carefully to determine which magnitude setting best achieves your test goals.
Tolerance	For step functions only. A step compression is considered achieved when the current microbeam position (or force) is at the specified magnitude +/- the tolerance. A tolerance that is too small may result in unacceptably long compression durations and/or instability. Recommended values are at least 10 times the force resolution of the beam. (see chapter: Force Calculation Formulas for more details).
Correct Overshoot	For step functions only. An overshoot is defined as a compression magnitude that is larger than the specified magnitude plus the tolerance. When checked the control software will move the microbeam up and/or down until the desired step magnitude is achieved (i.e. recover from overshoot). When unchecked, the control software will consider overshoot as the successful completion of the step function. Not correcting overshoot is important for relaxation testing.
Loading Duration	For evenly spaced images, it is recommended to choose a number that is an integer multiple of the Image Output Frequency.
Hold Duration	Hold Duration is typically set to 0, however it is useful for creep or relaxation testing.
Recovery Duration	Recovery Duration is often set to the same value as the Stretch Duration.
Do Not Recover	Select this to skip the recovery phase.
Rest Duration	Rest duration is typically set to 0, however a non-zero value may be used to mimic <i>in vivo</i> conditions or for specialized testing.
Repetitions	Apply enough repetitions until the force deformation curves from one repetition to the next start to overlie each other.
Data Output Frequency	Typically set to the same frequency as the image output frequency.
Image Output Frequency	Typically set to 1Hz for cycles > 30 seconds and 5 Hz for cycles < 30 seconds.

MicroTester G2 Tip: Multi-Stage Compression Testing

Recover phases can be skipped by checking the “Do Not Recover” check box. For example, a set that performed 10% compression with the “Do Not Recover” box checked would result in the specimen still being compressed by 10% at the start of the next cycle.

Multi-Stage compression can be achieved by performing multiple sets that have a “Do Not Recover” duration.

For example, to compress a specimen by 300um in 3 stages of 100um, create 3 separate sets (i.e. three separate lines in the test parameter specification table). The first set should have a 100um compression magnitude, the second a 200um compression magnitude, and the third a 300um compression magnitude. (Note the compression magnitude is relative to the start of the test rather than the position at the start of the set).

MicroTester G2 Tip: Testing Tissues that Relax Quickly

For specimens that relax very quickly, it may be necessary to achieve the desired move in 2 or 3 stages so as not to overshoot and rebound. What can happen in these cases is that the microbeam will achieve its desired displacement, completing the “Compress” phase. At the start of the hold phase, the tendency of the specimen is to relax, causing a drop-in force. This dropping force causes the microbeam to want to unload its elastic energy and hence further deform the specimen. The software will react to this by raising the stage (microbeam base) to reduce the applied force and maintain the desired displacement. The difficulty occurs when the relaxation causes these events to happen so quickly that the 5Hz operation of the equipment cannot keep up and maintain the desired displacement. The only remedy is to move the beam part way to its destination in 1 or more preliminary moves so that the overshoot that takes place never results in the microbeam moving more than its desired displacement.

MicroTester G2 Tip: Applying Preloads

Preloading can be implemented by creating a set with a force control step function load at the beginning of a testing sequence.

MicroTester G2 Tip: Tension Testing

The MicroTester G2 can be used to perform tension testing by fixing the specimen to the lower and upper compression plates. To achieve this, the compression magnitude should be entered as a negative number.

Step 3: Specify the Microbeam Properties (Occasional)

Microbeam properties including dimensions and modulus must be correctly specified to obtain correct force outputs. You can check and set Beam properties by selecting Equipment from the Settings menu or by pressing the Equipment Settings button in the Live Output section of the main display window. The following dialog will appear.

Note that the "Beam Length" parameter refers to the distance from the fixed end of the microbeam wire (the near side of the clamp) to the point of force application at the free end under the compression platen.

The microbeam length described above **MUST** be accurately measured. Calipers or a finely marked ruler can be used.

Standard microbeam diameters and moduli are shown in the table below. Potentially, other microbeams of other materials could be used. Microbeams may need to be cut before mounting to between 30-60 mm in length. Scissors or side-cutters may be used for this purpose.

For instructions on preparing and mounting a microbeam, see Section 9 of the manual - Mounting Microbeams.

Equipment Settings

Beam Properties

Rectangular
 Circular

Length (mm) 58 Thickness (mm) 0
Diameter (mm) 0.5588 Modulus (MPa) 411000

Camera

Shutter (mS) 5 Auto
Gain (0-100) 10 Auto
Resolution
2048x2048 24 bit color
Recommended Maximum Shutter = 10 mS

Auxiliary Camera

Shutter (mS) 0
Gain (0-100) 0
Resolution

Temperature

Setpoint (°C) 37
Warnings
 Show Warnings if Temperature Not within Setpoint Tolerance
Tolerance (Degrees C) 1

Grid Overlay

Show
spacing (pix) 100

Optics

Pixels Per um Per Zoom 0.33

OK Cancel

MicroTester G2 Tip: Update Templates After Changing Beam Properties

*It is important to update the beam properties after replacing a microbeam. **The beam properties are stored in the test template along with the test protocol and other equipment settings.** For these updated beam properties to be automatically used the next time you start a new test using the same template, you should save these settings to a new template using "Save As Template" from the File menu.*

Step 4: Load the Specimen

Loading the specimen under the microbeam takes a certain amount of practice. It is important to position the specimen as close as possible to the front glass so that it can be imaged correctly. The end of the microbeam can be used as a micromanipulator for this purpose. The microbeam can be moved using the manual Actuator Controls which allow the user to move each actuator independently at a variety of jog speeds.

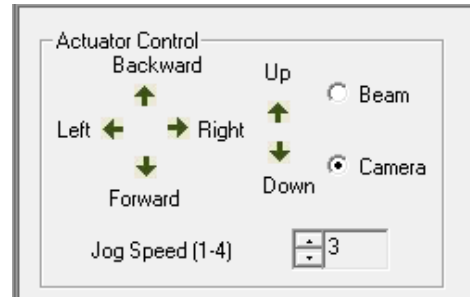

MicroTester G2 Tip: Viewing the Specimen in the Live Video Window

The optics and camera are mounted on three axis manual stages which can be used to focus and position the optics and camera to obtain optimal imaging.

The optics have a manual zoom control detent which can be used to change the magnification of the image and increase the field of view. It is often helpful to work at low zoom levels for loading a specimen. The zoom level can then be increased once the specimen is properly loaded.

Camera Shutter and Gain can also be adjusted (on the Equipment Settings dialog) if the live image appears too bright or too dark. See Section 6 for more details.

MicroTester G2 Tip: Microbeam Position

For most testing it is desirable to move the microbeam forward until it touches the glass and then move it backward a very small amount. It is usually obvious when the microbeam touches the glass because it will jump suddenly in the live image.

Step 5: Set the Optics Zoom Level

A zoom specification grid is located below the Actuator Control interface. The “Zoom” grid **MUST** be set correctly (at the same value as the zoom indicator on the lens) so that the software can convert image tracking data from pixel values to μm values.

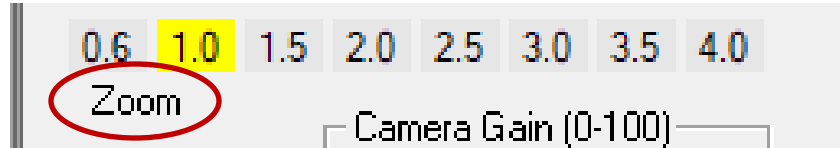

MicroTester G2 Tip: Setting a Default Software Zoom Level

The initial software zoom level is stored in the test templates. This value will be saved to the current selected value when saving a template using “Save As Template” from the File menu.

Step 6: Adjust the Initial Size Crosshairs

There are two red crosshairs overlaid on the live image. If the zoom level is set correctly, the “Initial Size” field on the left will display the distance between these crosshairs. The crosshairs can be moved on the screen by clicking on them and dragging them (they will turn yellow when they are clickable and can be dragged).

Usually the crosshairs are moved to be positioned at the top and bottom of the test specimen.

Note that the absolute distance is measured between the crosshairs, not the linear distance in one axis. Thus, the crosshairs must be aligned horizontally if a correct vertical distance is to be measured.

Initial Size is one of the outputs in the .csv data output file.

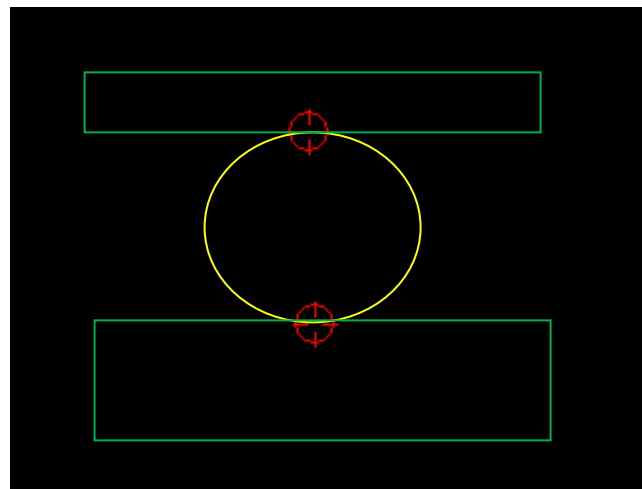

Step 7: Select a Tracking Point

Select an appropriate tracking point on the microbeam or compression plate by **right-clicking** on the live video window. A green rectangle or square will appear showing the region that will be used to track this location. The selected point should have some contrast (light/dark) within the green rectangle and should not change in appearance due to lighting glare (i.e. it should be a real feature, not an effect created by the lighting). Since force calculations are based on the tracked point locations, accurate tracking is essential for accurate force outputs.

Good choices for the tracking point location, as shown in the following figure, include locations on the microbeam wire end or on the compression plate attached to the microbeam. Features in focus tend to track better than features that are out of focus or blurry.

Good choices on the microbeam include regions of high contrast within the rectangle. A poor location (shown in red) on the microbeam does not have enough contrast within the rectangle for the tracking algorithm to uniquely determine its location.

Good choices on the compression plate will span across a sharp boundary with, for example, the bottom half of the green tracking rectangle covering the compression plate and the top half of the tracking rectangle not on the compression plate. Poor choices on the compression plate (shown in red) include locations that are overlapping with or close to the specimen (which may change in appearance during compression) or do not span across one of the plate edges.

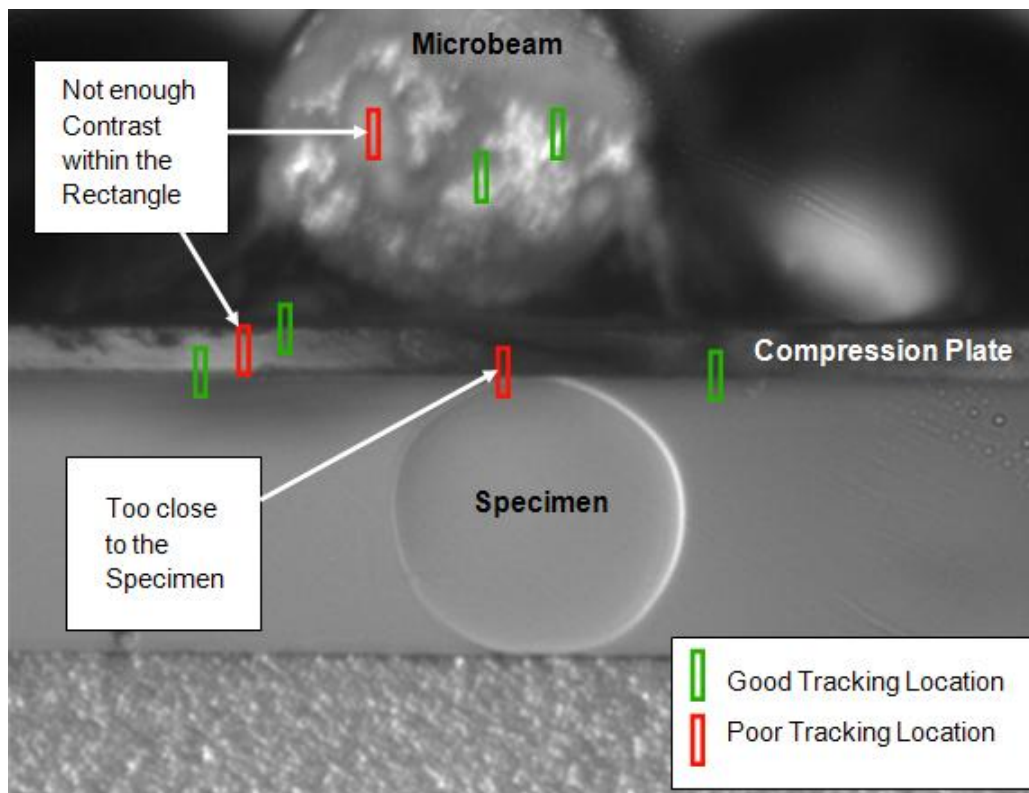

Step 8: Execute the Test

Select Execute from the File menu, or click  on the toolbar.

MicroTester G2 Tip: Check Settings

Before executing a test, be sure that the microbeam properties and optics zoom level are set correctly. Accurate results are highly dependent on these settings. Also check the position of the initial size crosshairs and tracking point.

Step 9: Terminate the Test Prematurely (optional)

You can stop a test at any time by clicking  on the toolbar, or by selecting Stop from the File menu.

6. Additional Settings

Camera Shutter and Gain

Camera settings can be adjusted by selecting Equipment from the Settings menu or by pressing the Equipment Settings button in the Live Output section of the main display window. The following dialog will appear.

Increasing the camera shutter duration or the camera gain makes the image brighter. Decreasing either of these parameters makes the image darker. If the gain is too large, the image may appear grainy. If the shutter is too long, the image may appear blurry. These settings are stored with the test template file.

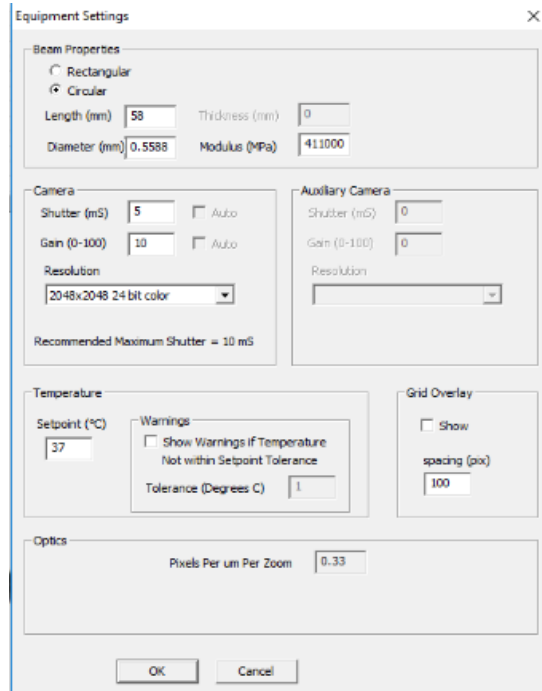

Grid Overlay

Within the Equipment Settings menu, a grid overlay option can be implemented during a trial. The spacing can be manually inputted (in pixels). Checking the Show check box will display a green grid with the specified spacing.

Applying a grid overlay can provide many benefits during a trial such as distance referencing, beam alignment checking, and quadrant mapping.

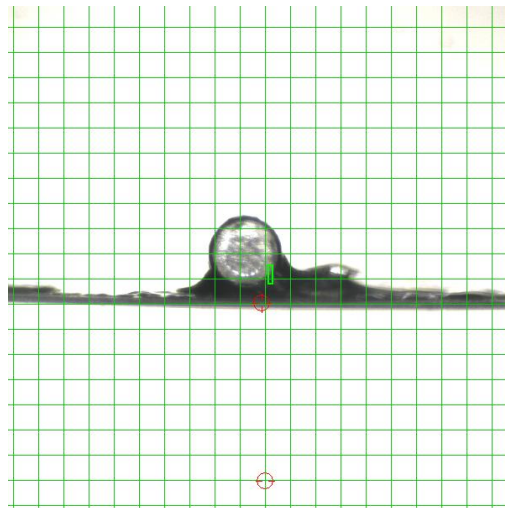

Temperature

To activate the fluid chamber heater, not only must the ON/OFF switch be turned on, but the "ENABLE" button must be pressed so that the HEATER ON indicator is illuminated. At this point, the heater will warm the fluid to the last used temperature set point. The temperature set point can be changed by selecting Equipment from the Settings menu.

Typically, the heater will take 10 to 30 minutes to warm a full fluid chamber from room temperature to 37°C.

When Show Temperature Warnings is enabled, and the Current Temperature is not at the Temperature Set Point plus or minus the specified tolerance -- a red indicator button will be displayed next to the Current Temperature live output and a warning dialog will appear when you execute the test.

Test Sequence

Temperature Set Point: 37

Total Time: 00:00:45

Set Name	Axis	Magnitude	Load(S)	Hold(S)	Recover(S)	Rest(S)	Reps	Data(Hz)	Image(Hz)	Parameters
Data1	Z-Compress	Ramp 200.0 (um)	20	5	20	0	1	5	1	

Configuring the Real-Time Graphs

The three graphs on the right side of the screen provide real-time user feedback during a test. These graphs are intended to be used for qualitative feedback, not for detailed analysis.

The graph settings can be specified by selecting Graphs from the Settings menu. Auto scaling allows the axis min and max to start at the specified values but expand if the data values are larger or smaller than the initial limits.

The screenshot shows a 'Graph Settings' dialog box with three sections for Graph 1, Graph 2, and Graph 3. Each section contains XAxis and YAxis settings. The XAxis settings include a dropdown menu for the variable, a dropdown for 'Auto' scaling, and input fields for 'Min' and 'Max' values. The YAxis settings include a dropdown menu for the variable, a dropdown for 'Auto' scaling, and input fields for 'Min' and 'Max' values. A 'Clear Graph Between Sets' checkbox is located at the bottom of each section. The 'Clear Graph Between Sets' checkbox is checked for Graph 3. At the bottom of the dialog are 'OK' and 'Cancel' buttons.

It is typical to display Force versus Time, Displacement versus Time and Force versus Displacement as shown below. However, any of the following variables can be plotted in any of the three graphs:

Force (μN)	Displacement (μm)	Time (S)
Force (mN)	Displacement (mm)	Temperature

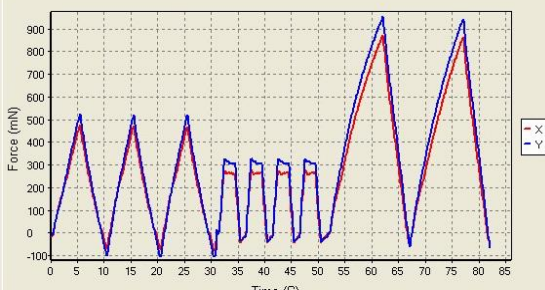
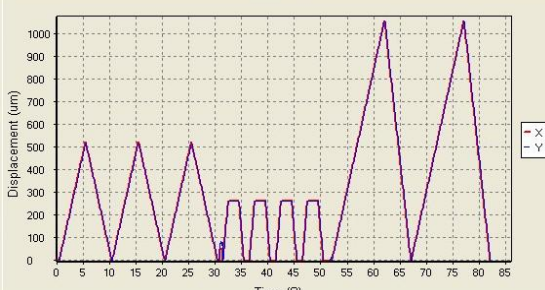
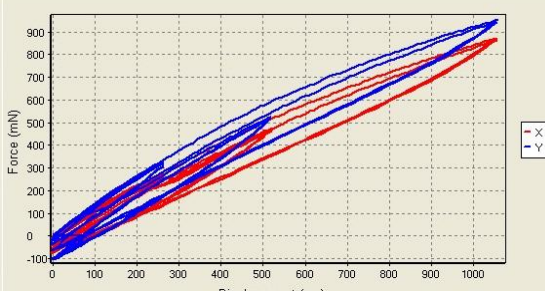
Graph	Data
<p>Force versus Time</p> <p>This graph shows how the measured forces are changing with time. Peak loads per cycle, and force relaxation are all easily seen in this type of graph. Force is proportional to nominal (engineering) stress.</p>	
<p>Displacement versus Time</p> <p>This graph shows how the microbeam is moving with time. The phases of the test sequence are readily apparent in this type of graph. Displacement is proportional to nominal (engineering) strain.</p>	
<p>Force versus Displacement</p> <p>This graph displays a qualitative representation of the material behavior. Viscoelastic effects (like hysteresis) and material response to different loading phases are apparent in this graph. This graph is proportional to a nominal (engineering) stress-strain graph.</p>	

Data Output Settings

Select Data Output from the Settings Menu and the following dialog will appear.

The .jpg image file quality that will be used for saving collected images.

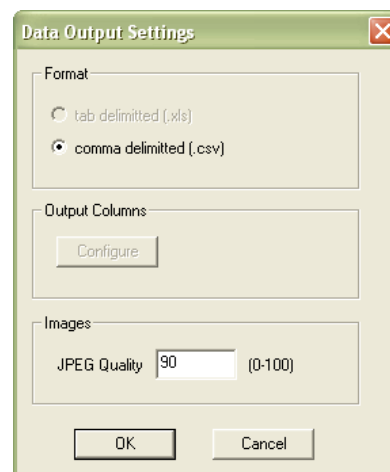

Output column units can be configured by selecting the “Configure” button. By default “Smart Default Units” will be selected. This feature will auto select appropriate units for the data collected. Select “Use Custom Units” to select desired units instead.

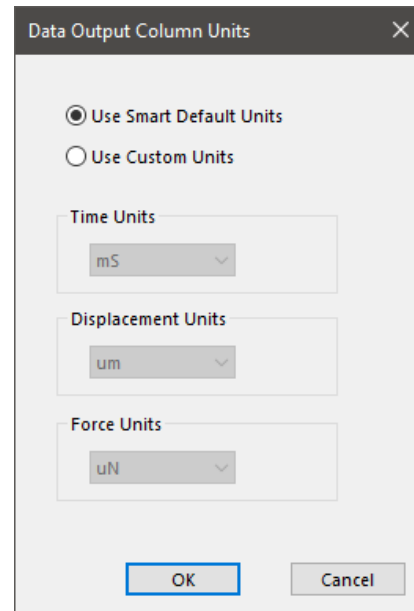

Advanced Settings

Select Advanced from the Settings menu and the following dialog will appear.

Hold Phase Control allows the user to set some limits on actuator movement, in order to improve system stability.

The first parameter limits the maximum movement of the vertical stage during each control loop iteration.

The second parameter (“Slow Ratio”) is like a safety factor. For example, if a move of 10µm is desired in each time step, the actuator will attempt to move 10µm X the slow ratio. See the tip below for more information.

Image Tracking Settings allow users to control the size of the search region and the size of the tracking template. These parameters should normally not be changed.

For systems equipped to measure the X-Shear axis, a square template and search region is recommended.

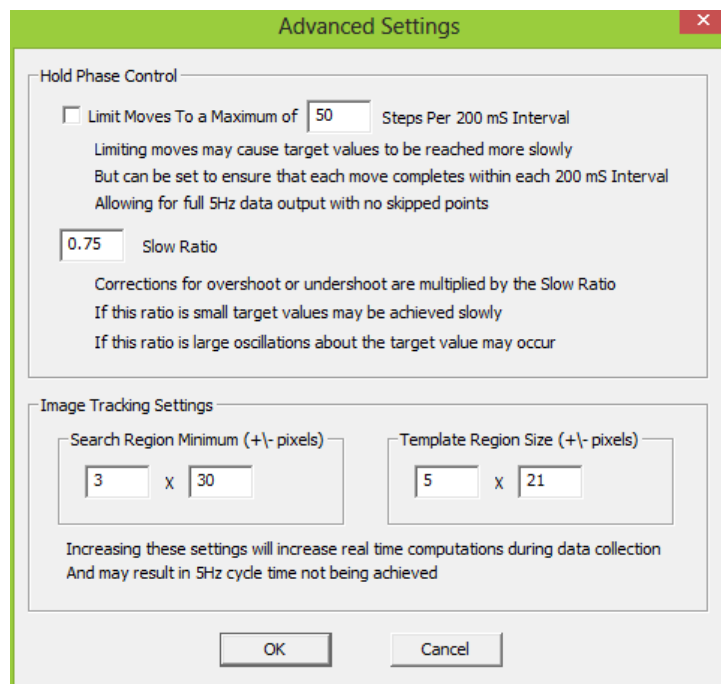

MicroTester G2 Tip: Slow Ratio

For the hold phase of linear elastic materials, both the beam tip and beam base will remain close to stationary during a hold phase, so a slow ratio of 0.3-0.5 is appropriate to improve stability. For highly viscoelastic materials, the beam tip will tend to keep moving downward at the end of the compression phase, resulting in increasing compression and decreasing applied force (due to decreasing beam deflection). To counteract this, the software will have to move the beam base upward for a displacement-controlled test (to maintain the current displacement) or downward for a force-controlled test (to maintain the current force). In these situations, a higher slow ratio may be needed. A ratio of 0.75-1.0 is relatively stable. Higher ratios will be even more responsive, but also potentially more unstable. Trial and error may be required to obtain the optimal results for your material.

7. Reviewing Test Results

The MicroTester includes an additional software, Data Analysis, to review and analyze data collected from the device. This includes graphing, curve fitting, material modeling and image processing to determine detailed strain maps.

To open the Data Analysis program, select File>Analyze and Review Images from the MicroTester software home page. More details about Data Analysis can be found in its user manual located in the Documentation folder (Cellscale>MicroTester>Documentation).

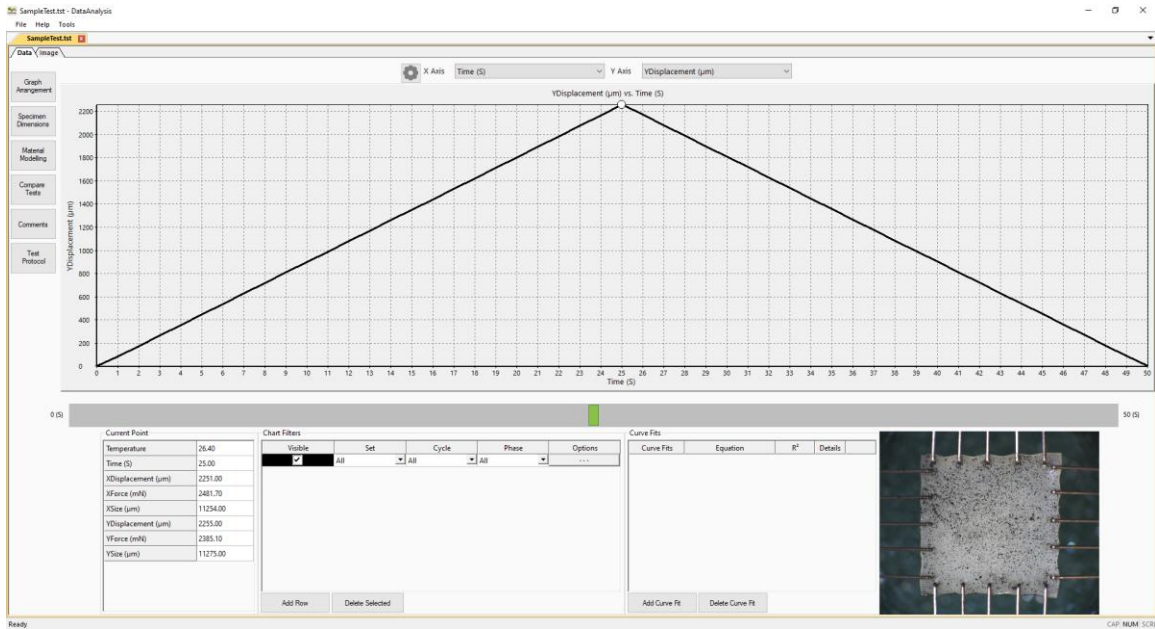

8. System Calibration and Advanced Tools

Piezo Calibration

Piezo Calibration can be selected from the Calibrations submenu of the Tools menu.

While the vertical piezo stage relies on the displacement sensor for determining the amount of travel, a calibration routine is necessary so that the software can estimate the correlation between movement pulses and displacement. This calibration routine will attempt to move the piezo actuator a certain amount and will measure the actual movement achieved. It is recommended that the piezo calibration be performed when the equipment is being set up for the first time in your facility. It is also required to be performed whenever the MicroTester G2 software is used on a new computer as the calibration factor is stored on the computer.

Before calibration, make sure the vertical piezo stage is in the mid-range of its travel, preferably at the height from which a test will be started.

The calibration results are reported in the log window on the left side of the main screen.

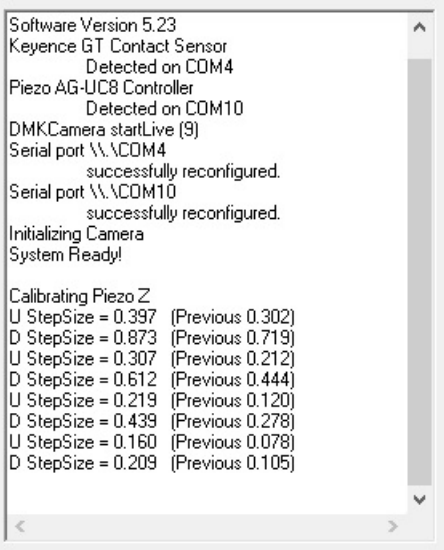

```
Software Version 5.23
Keyence GT Contact Sensor
    Detected on COM4
Piezo AG-UC8 Controller
    Detected on COM10
DMKCamera startLive (9)
Serial port \\.\COM4
    successfully reconfigured.
Serial port \\.\COM10
    successfully reconfigured.
Initializing Camera
System Ready!

Calibrating Piezo Z
U StepSize = 0.397 (Previous 0.302)
D StepSize = 0.873 (Previous 0.719)
U StepSize = 0.307 (Previous 0.212)
D StepSize = 0.612 (Previous 0.444)
U StepSize = 0.219 (Previous 0.120)
D StepSize = 0.439 (Previous 0.278)
U StepSize = 0.160 (Previous 0.078)
D StepSize = 0.209 (Previous 0.105)
```

Optics Calibration

Optics calibration must be completed when the system is first set up and every time the camera and lens system is disassembled or changed. It must also be performed every time a new computer is used to run the MicroTester G2. The procedure is as follows:

1. Launch the MicroTester G2 software and launch a new test in order to see the live video window.
2. Bring up the Optics Calibration Dialog by selecting Optics Calibration from the Calibrations submenu of the Tools menu.
3. Position a calibrated target with features of known size on the front of the fluid chamber. A glass target with 10 lines/mm (1mm = 1000 μm) is provided with your equipment for this purpose. This target can be positioned with provided holder. Focus the Image using the three axis stages on which the optics and camera are mounted.
4. Drag the crosshairs on the live video window such that they are positioned a known distance apart. Be sure that the crosshairs are **aligned with each other** as the computer measures the **absolute distance** between them, not just the horizontal or vertical distance.
5. Enter the distance between the crosshairs in the dialog field.
6. Select the optics zoom level.
7. Click the “Calibrate” button in the dialog box.
8. Selecting the “Apply” button will cause the software to use the current calibration value. It is useful to compare the current calculated value with the previous value as the value should not change dramatically. A typical calibration value is around **0.32 pixels/ $\mu\text{m}/\text{zoom}$** .

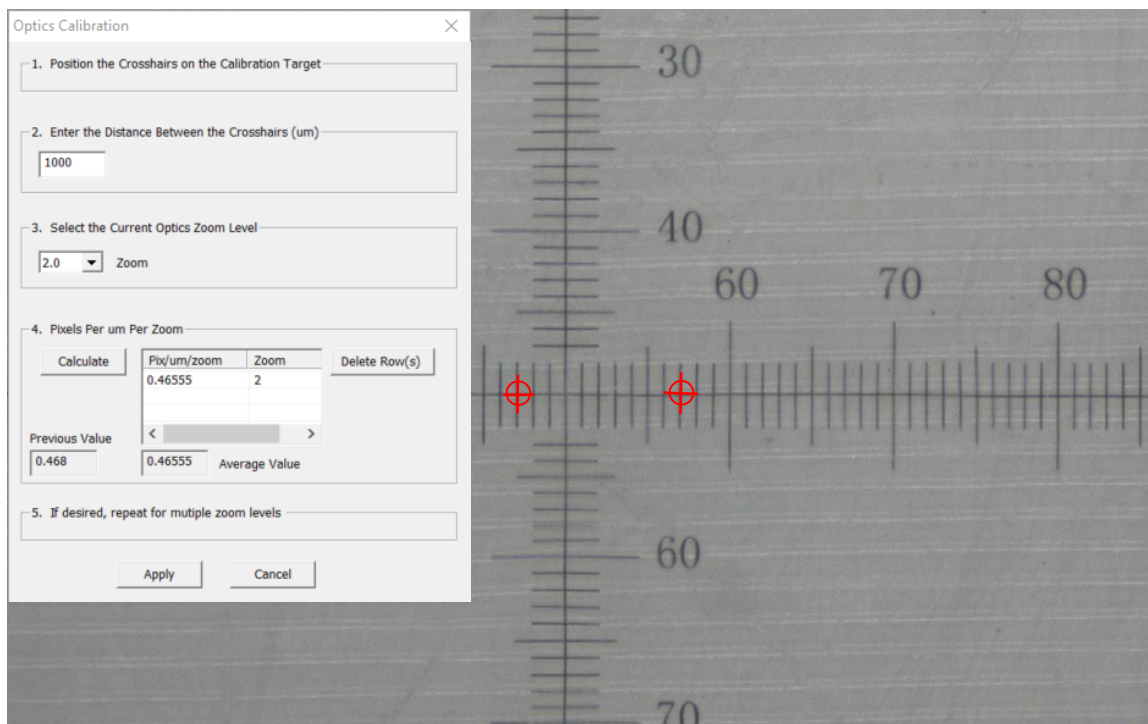

Snap Image

Single Images can be captured and saved from the live video stream by selecting Snap Image from the Tools menu.

This feature allows the user to capture a single image during the setup phase. This can be useful for documenting specimen loading activity and neutral (non-contact) beam position.

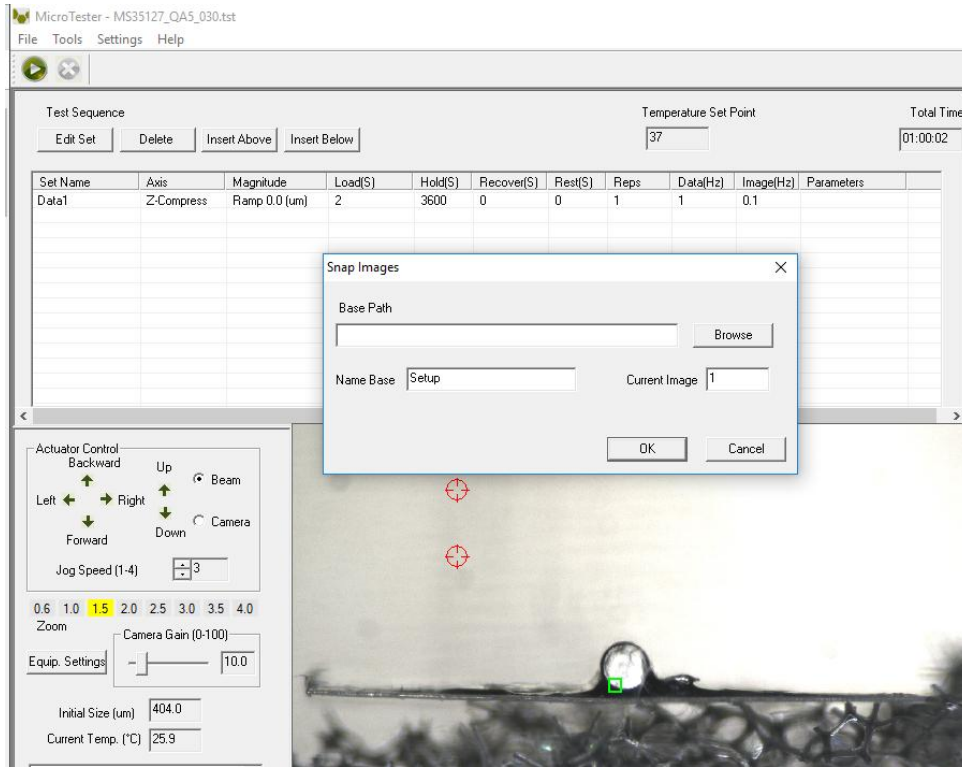

Beam Calibration

Microbeams can be calibrated using specialized fixtures and calibrated weights. These are non-standard parts for the MicroTester system. If this is required for your test procedures, contact support@cellscale.com.

To use custom beam calibration, open the Advanced Settings window under the Setting menu and check the “Enable custom beam calibration” box.

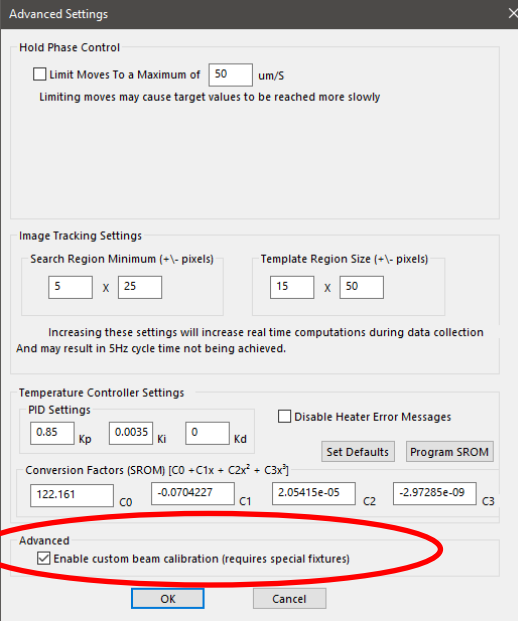

Advanced Settings

Hold Phase Control

Limit Moves To a Maximum of 50 um/s
Limiting moves may cause target values to be reached more slowly

Image Tracking Settings

Search Region Minimum (+/- pixels) 5 X 25 Template Region Size (+/- pixels) 15 X 50

Increasing these settings will increase real time computations during data collection And may result in 5Hz cycle time not being achieved.

Temperature Controller Settings

PID Settings Disable Heater Error Messages

0.85 Kp 0.0035 Ki 0 Kd Set Defaults Program SROM

Conversion Factors (SROM) [C0 + C1x + C2x² + C3x³]

122.161 C0 -0.0704227 C1 2.05415e-05 C2 -2.97285e-09 C3

Advanced

Enable custom beam calibration (requires special fixtures)

OK Cancel

Open the Beam Calibration window by navigating to the Tools>Calibrations>Beam Calibration. The beam calibration uses image tracking to detect the deflection from known applied weights.

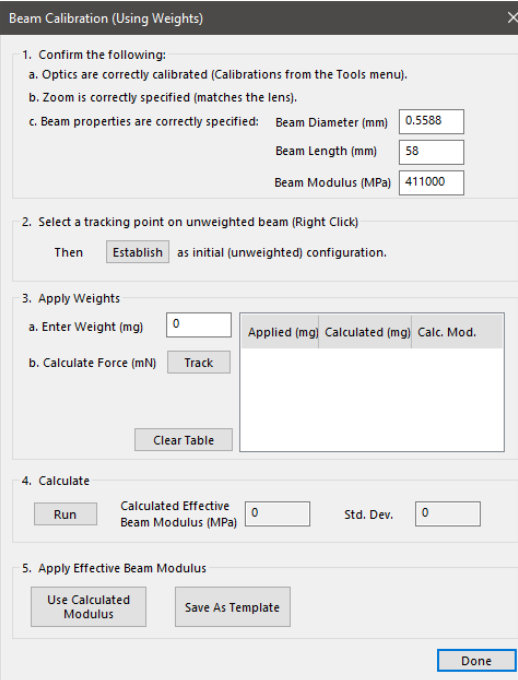

Beam Calibration (Using Weights)

1. Confirm the following:

- a. Optics are correctly calibrated (Calibrations from the Tools menu).
- b. Zoom is correctly specified (matches the lens).
- c. Beam properties are correctly specified: Beam Diameter (mm) 0.5588
Beam Length (mm) 58
Beam Modulus (MPa) 411000

2. Select a tracking point on unweighted beam (Right Click)
Then Establish as initial (unweighted) configuration.

3. Apply Weights

- a. Enter Weight (mg) 0 Applied (mg) Calculated (mg) Calc. Mod.
- b. Calculate Force (mN) Track

Clear Table

4. Calculate

Run Calculated Effective Beam Modulus (MPa) 0 Std. Dev. 0

5. Apply Effective Beam Modulus

Use Calculated Modulus Save As Template

Done

9. Mounting a MicroBeam

The exact details of how to best adhere the upper compression plate and mount the microbeam to the grips may vary depending on your specific application, but a general protocol is outlined here:

1. Gather the following materials:
 - a. Vertical mounting stage
 - b. 1.5mm Hex key
 - c. 5/64" hex key
 - d. Cyanoacrylate (i.e. Crazy Glue or Loctite 422)
 - e. Glue Accelerator
 - f. Cotton Swab
 - g. Tweezers
 - h. Microbeam clamp with M3 fastener
 - i. Desired microbeam and compression plate



2. Bring the vertical stage to its highest point by rotating the knob on the left side. If the stage does not move, release the stopper on the right side by rotating and loosening the side screw.

3. Align the microbeam clamp to the lip on the face of the stage, and fasten it using a 2.5mm hex key and M3 fastener

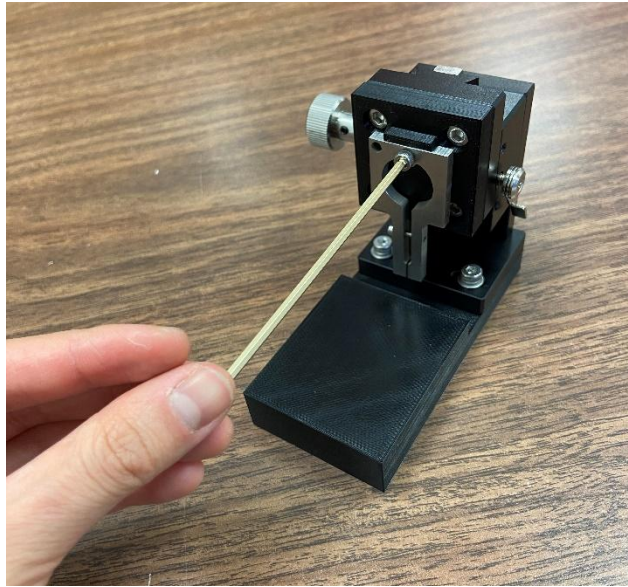

4. Loosen the side screw of the microbeam clamp using a 5/64" hex key



5. Place microbeam below the clamp opening and lower the stage until the beam is just above the tips of the clamp. Tighten the clamp using a 5/64" hex key. This is to ensure the microbeam is horizontal. Lift the stage slightly to ensure it is secure affix in the clamp

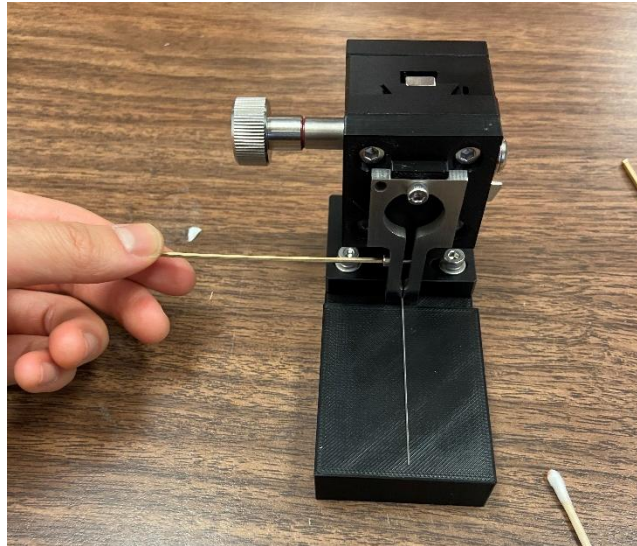

MicroTester G2 Tip: Microbeam Position

Very thin and/or delicate microbeams will tend to sag under their own weight (e.g. 100 μ m diameter and smaller metal microbeams). To ensure that the upper compression plate is level after mounting, it may be desirable to initially place the microbeam on an inclined surface.

6. Place the desired compression plate below the tip of the microbeam. Use tweezers to help ensure the tip of the microbeam is in line with the edge of the compression plate

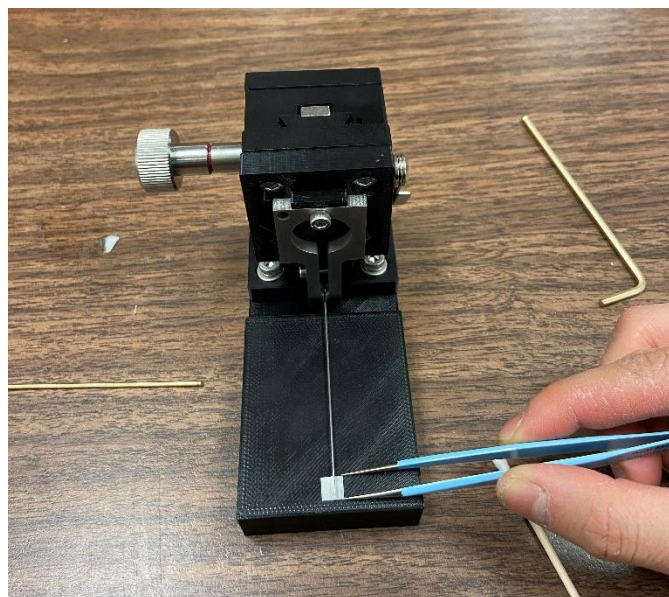

7. Place a small dab of glue on the tip of a cotton swap, and place this on the tip of the microbeam

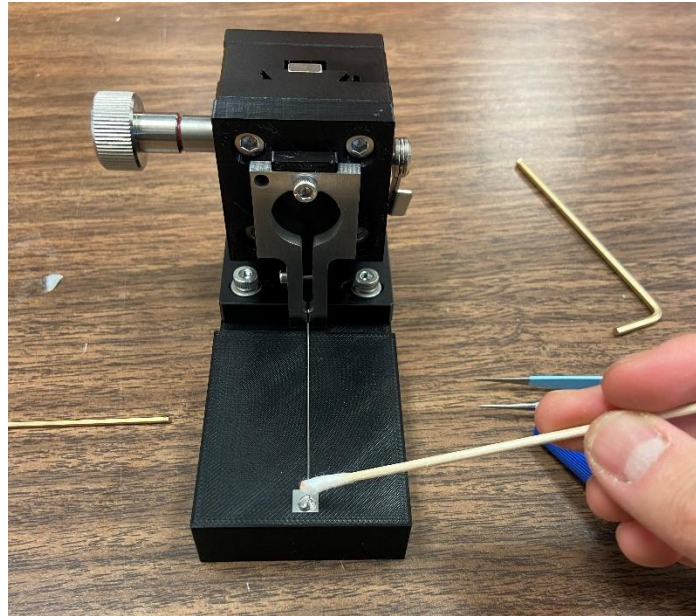

MicroTester G2 Tip: Cyanoacrylate Adhesive

*Cyanoacrylate adhesive is provided complimentary with the MicroTester G2 system to bond the microbeam and compression platen. This adhesive will best retain its properties if it is **refrigerated** when not being used.*

8. Lower the microbeam until it touches the plate
9. Cure the glue by brushing a small amount of glue accelerator

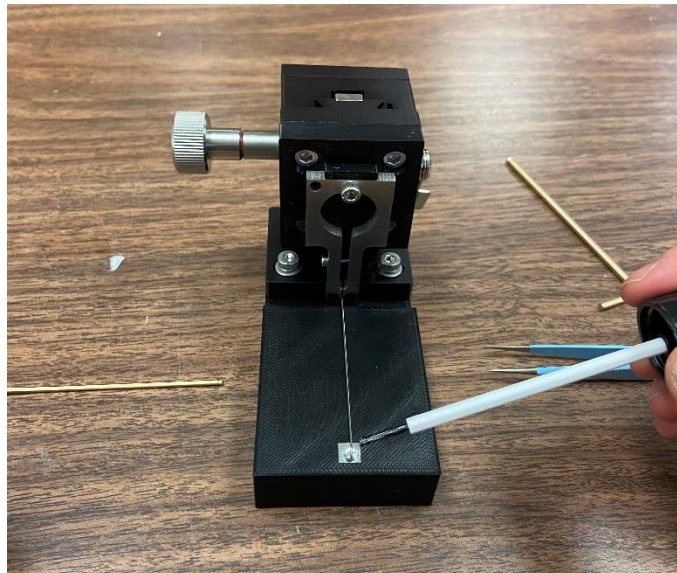

10. Lift the stage and remove the clamp from the stage using a 2.5mm hex key to loosen the M3 fastener



11. The clamp and microbeam assembly is ready to be mounted to the MicroTester system using the M3 fastener and 2.5mm hex key

MicroTester G2 Warning: Adhesive and Accelerator

Cyanoacrylate adhesive and accelerator are provided with the MicroTester G2 system to bond the microbeam and compression platen. These are eye, skin, and respiratory irritants. Cyanoacrylate will instantly bond skin. The use of gloves is recommended.

The microbeam clamp is attached to the vertical piezo stage with a single M3 fastener. This single connection allows for the angle of the upper compression plate to be adjusted under guidance from the live image. It is important that the upper compression platen and the lower compression anvil are parallel for proper compression testing.

The microbeam length must be measured and the dimensions and modulus correctly specified before a test. See Section 3 - Step 5 for more details.

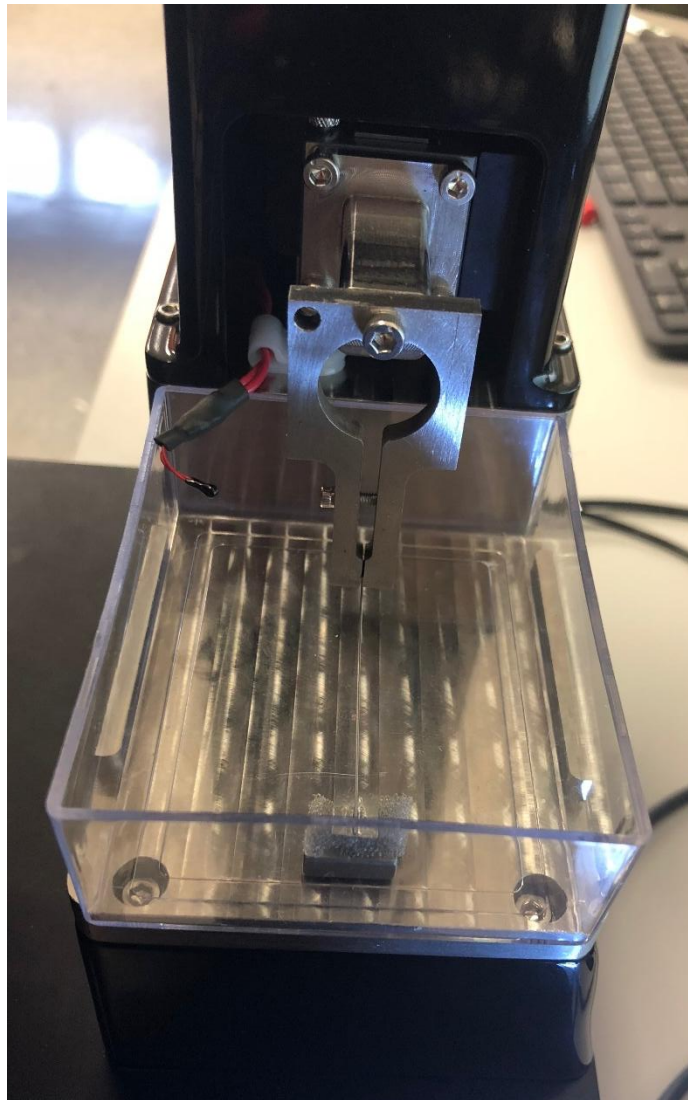

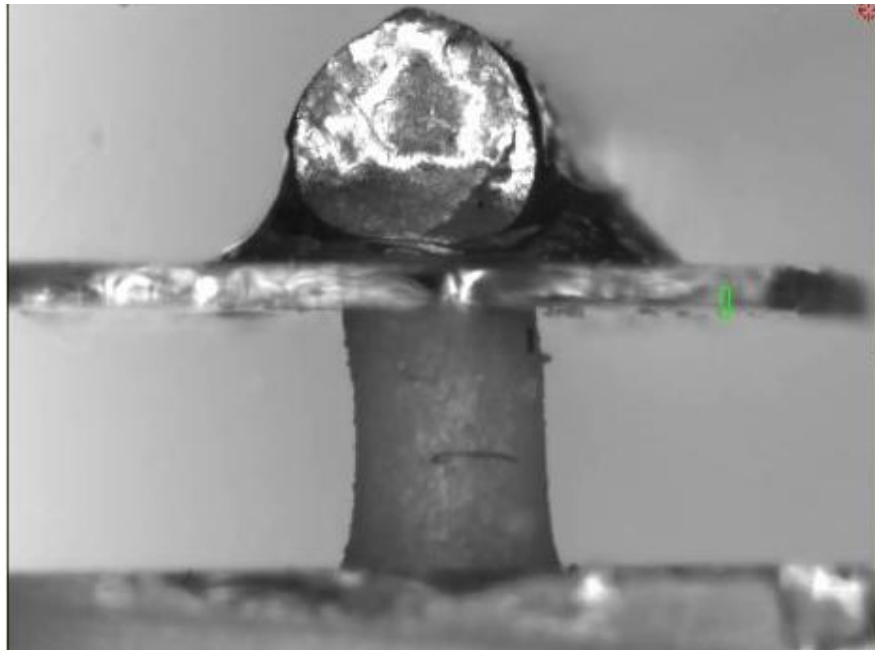
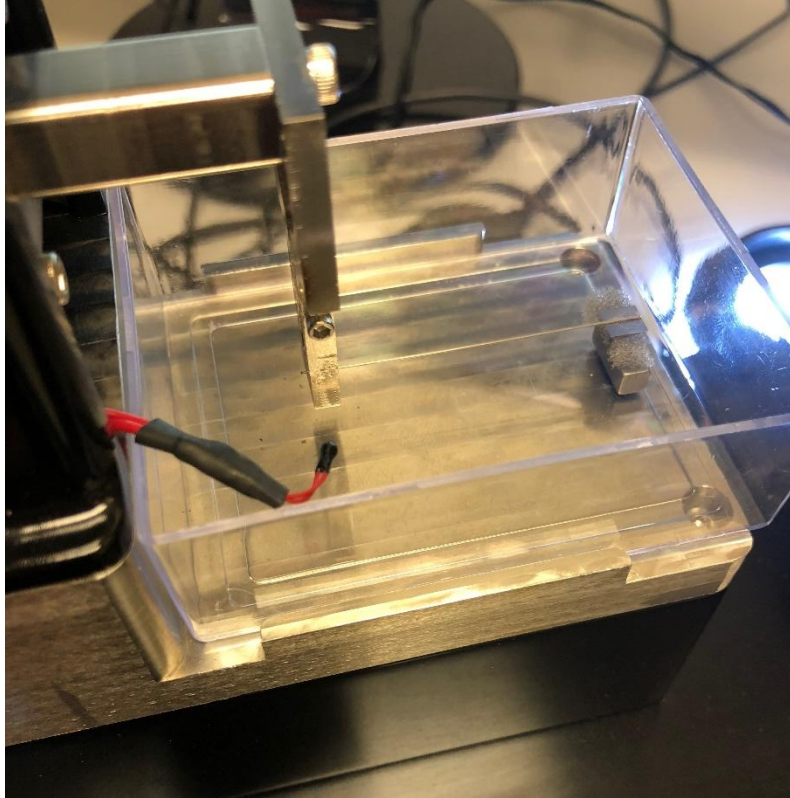

10. Force Calculation Formulas

The force applied to the specimen is calculated using the deflection of the microbeam according to the formula:

$$Deflection = \frac{Force \times Beam Length^3}{3 \times Beam Modulus \times Beam Area Moment of Inertia}$$

where

$$Beam Area Moment of Inertia (round) = \frac{\pi \times radius^4}{4}$$

$$Beam Area Moment of Inertia (rectangular) = \frac{Width \times Height^3}{12}$$

Typically, the microbeams are made from tungsten wire. CellScale has this wire available in 7 different diameters. With a beam length of 55mm, the expected force resolutions and recommended maximum forces are given below.

Diameter (mm)	0.0762	0.1016	0.1524	0.2032	0.3048	0.4064	0.5588
Modulus (MPa)	411000	411000	411000	411000	411000	411000	411000
Typical Force Resolution (μN)	0.012	0.038	0.191	0.604	3.056	9.658	34.52
Recommended Max Force (μN)	4	11	57	181	917	2,897	10,536

11. Appendix A: System Setup

Unpack Main Unit, Controllers, and Accessories

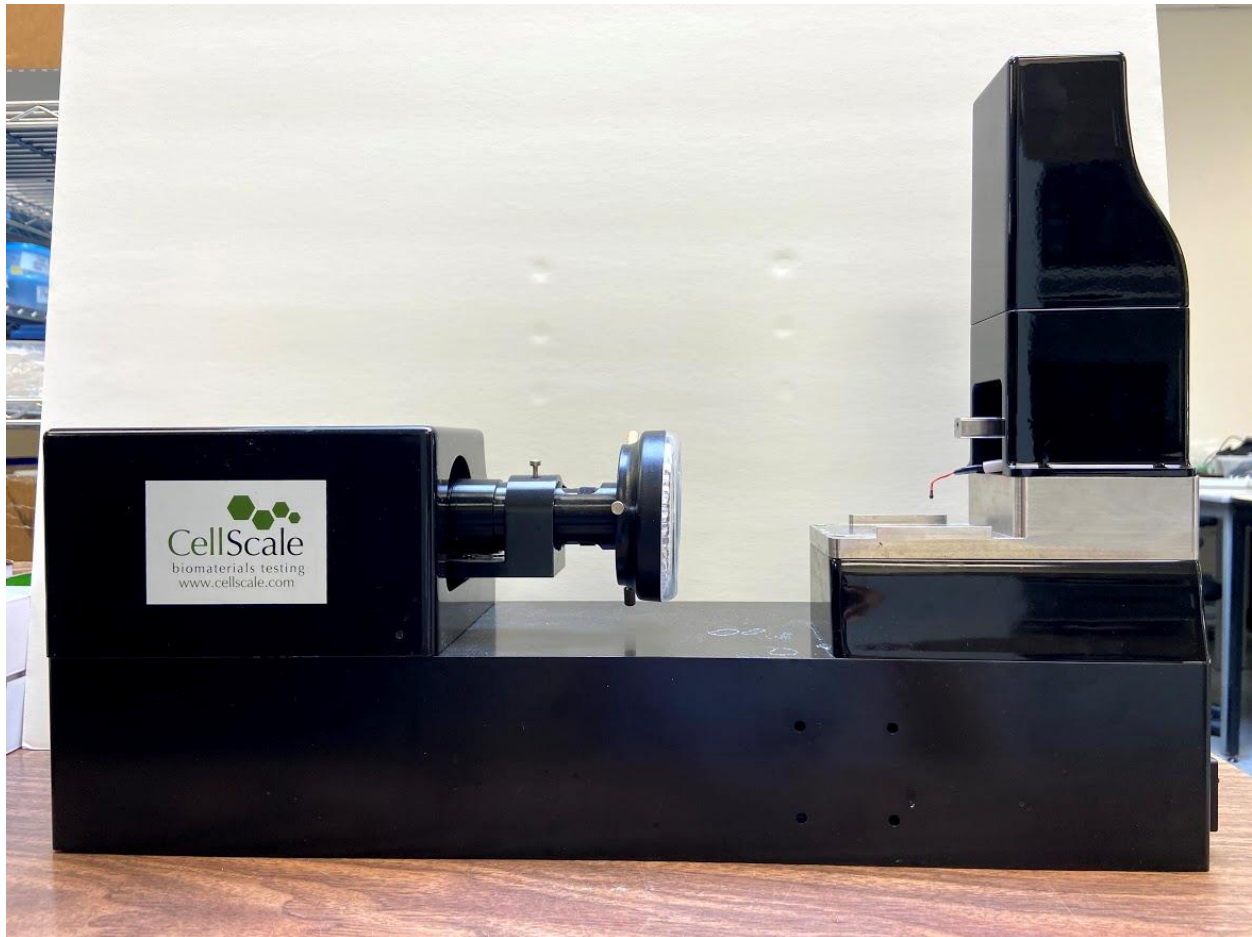

Remove the main unit from its packing material. A foam “clamshell” encases the main unit inside a cardboard box for shipping. This material must be carefully removed. Take care not to lift the main unit by the camera lens or positioning knobs.

The temperature controller, piezo stage controller, control box, and all system cables and accessories are packed in a separate container.

Foam Removal from Piezo Stack

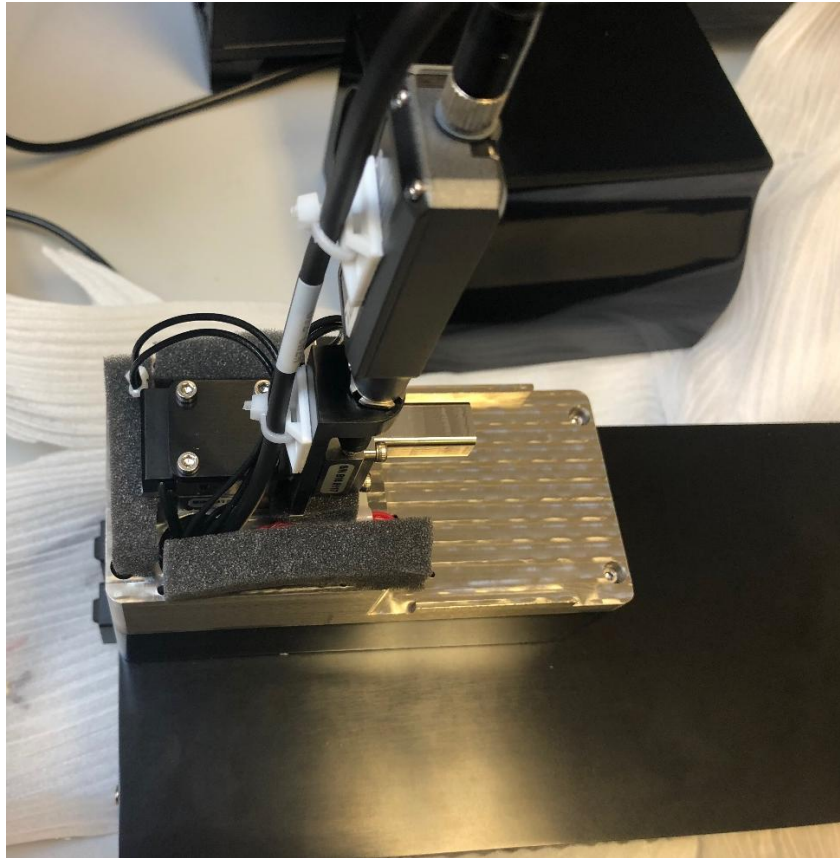

The piezo actuator stack and displacement sensor are protected by a plastic cap. Foam surrounds these components inside the cap during shipping. Remove the cap using a hex key and remove all pieces of foam inside. Replace the cap and fasteners.

Attach Spacer to Vertical Piezo Stage

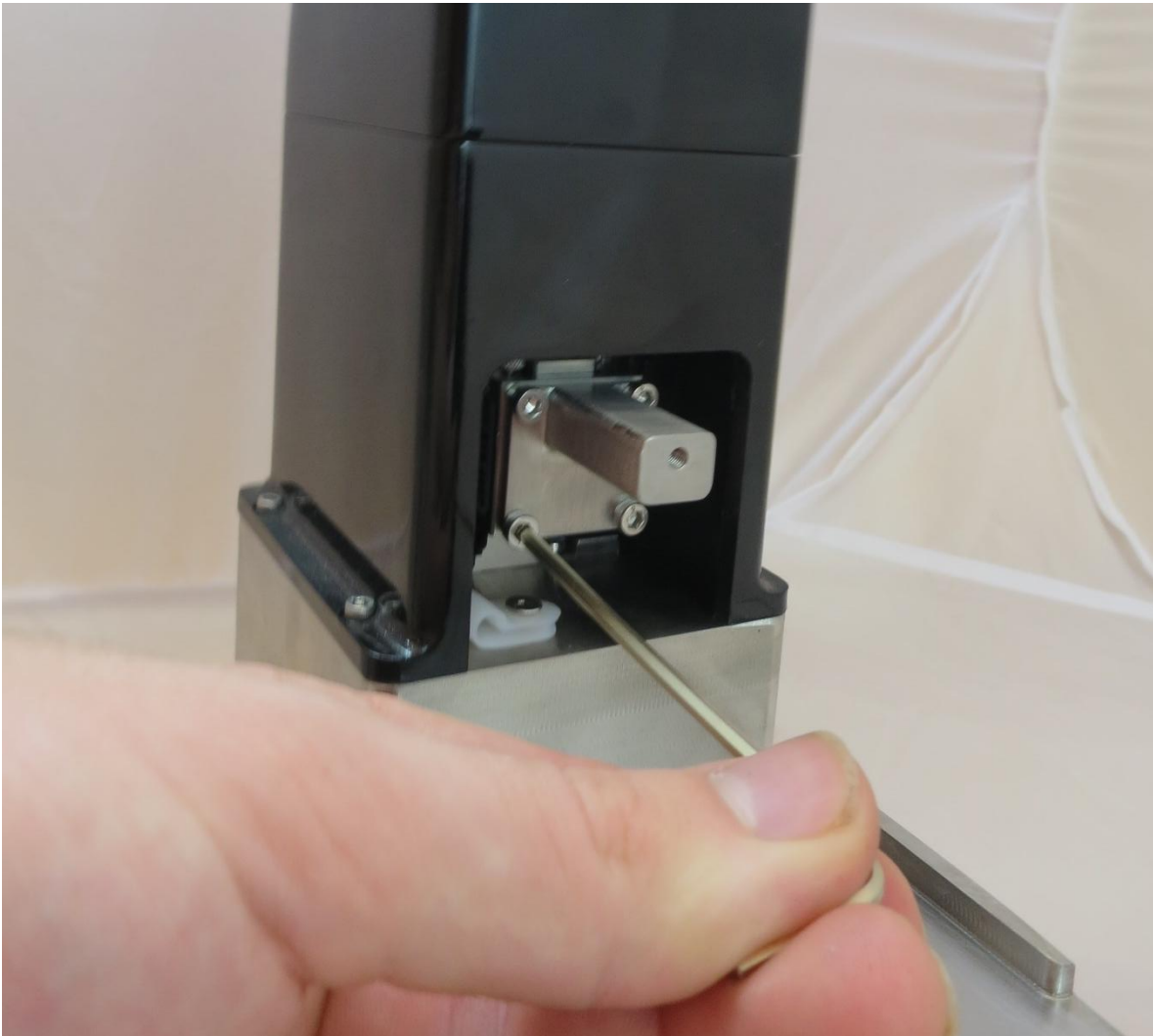

A spacer is attached to the vertical piezo stage. This allows the microbeam clamp to reach the test chamber. 4 x M3x6 fasteners are used to attach this component using the supplied 2.5mm hex key.

Camera Unpacking and Assembly

Remove the plastic cover over the camera stage using the long T-handle 3mm hex key to loosen 3x M4 screws.

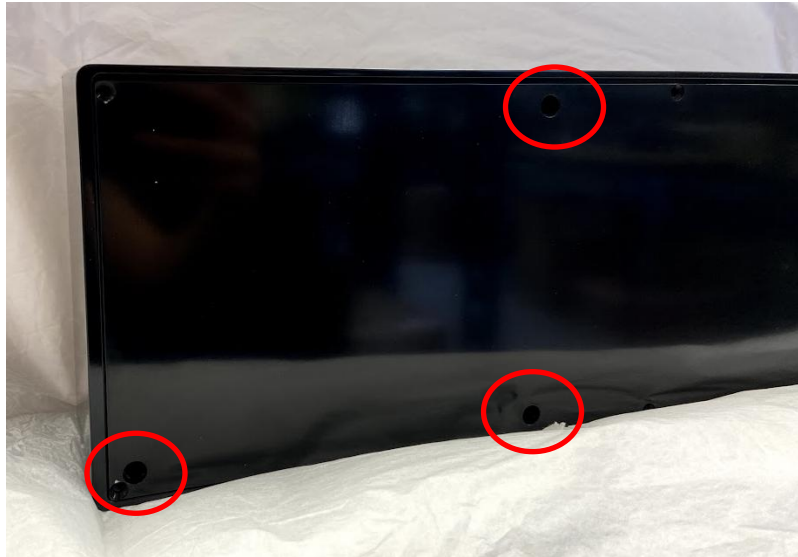

Remove the foam surrounding the camera stage and inside the camera cover.

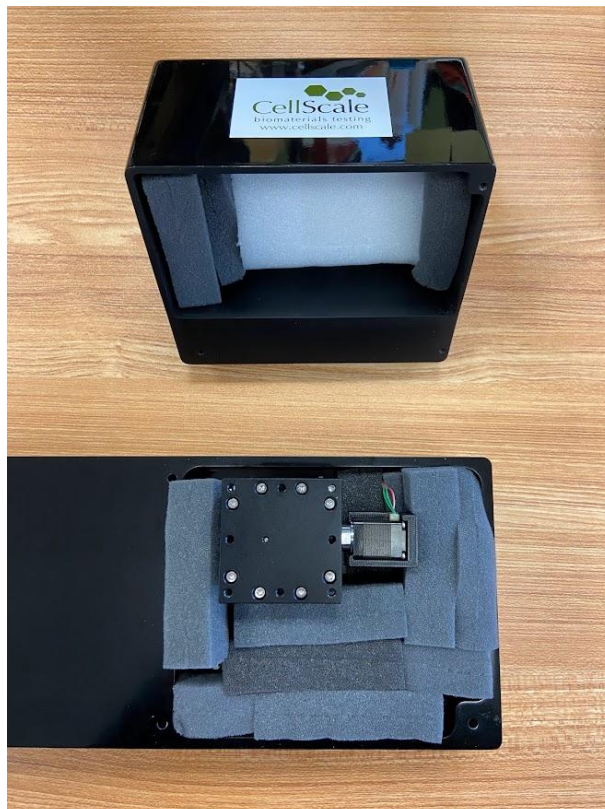

The stage is held in place with zip ties and plastic spacer blocks for shipping. Cut the zip ties shown below.

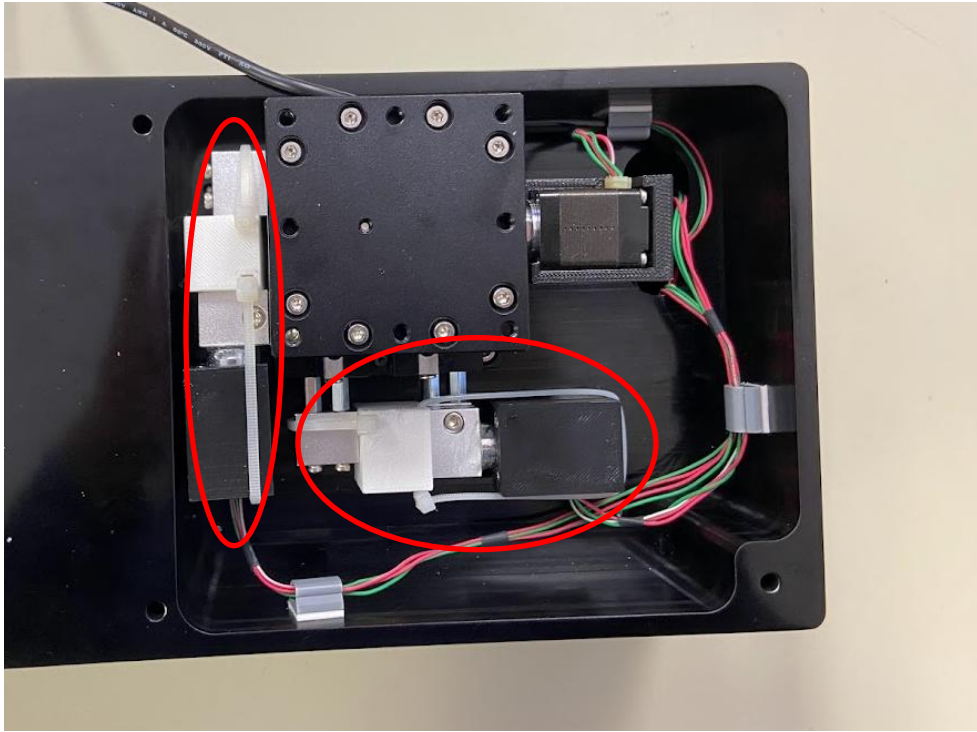

First slide the Left/Right stage in the direction below to remove the plastic spacer block. **Gently retract the stages back towards the motor.** The stages are spring loaded and releasing them at full tension can result in damage to the motors and/or linear stage itself.

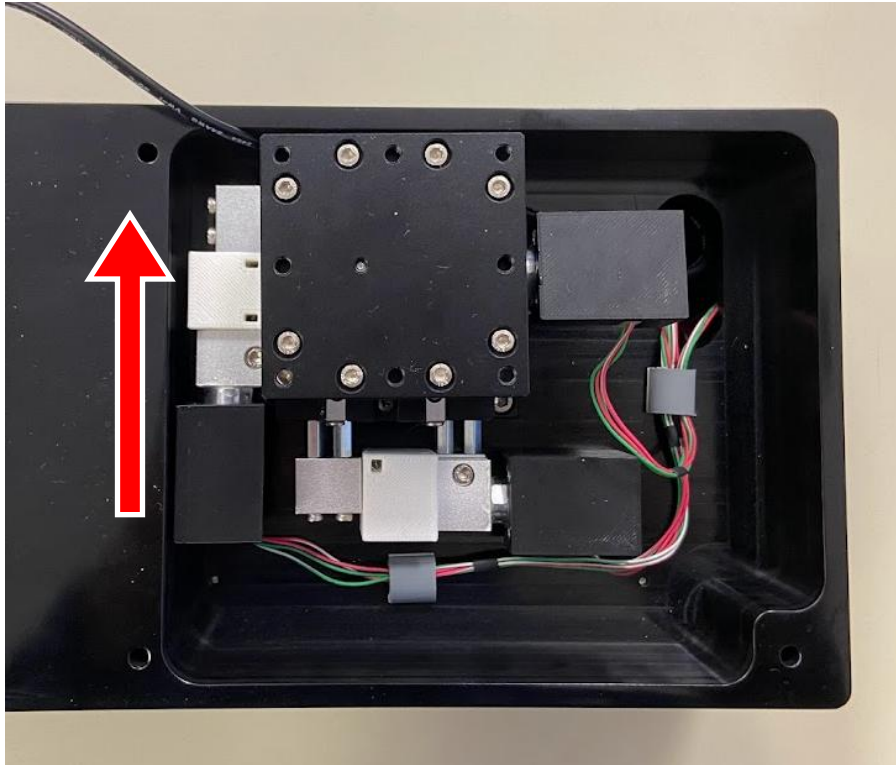

Next slide the Forward/Backward stage in the direction below to remove the plastic spacer block. **Gently retract the stages back towards the motor.** The stages are spring loaded and releasing them at full tension can result in damage to the motors and/or linear stage itself.

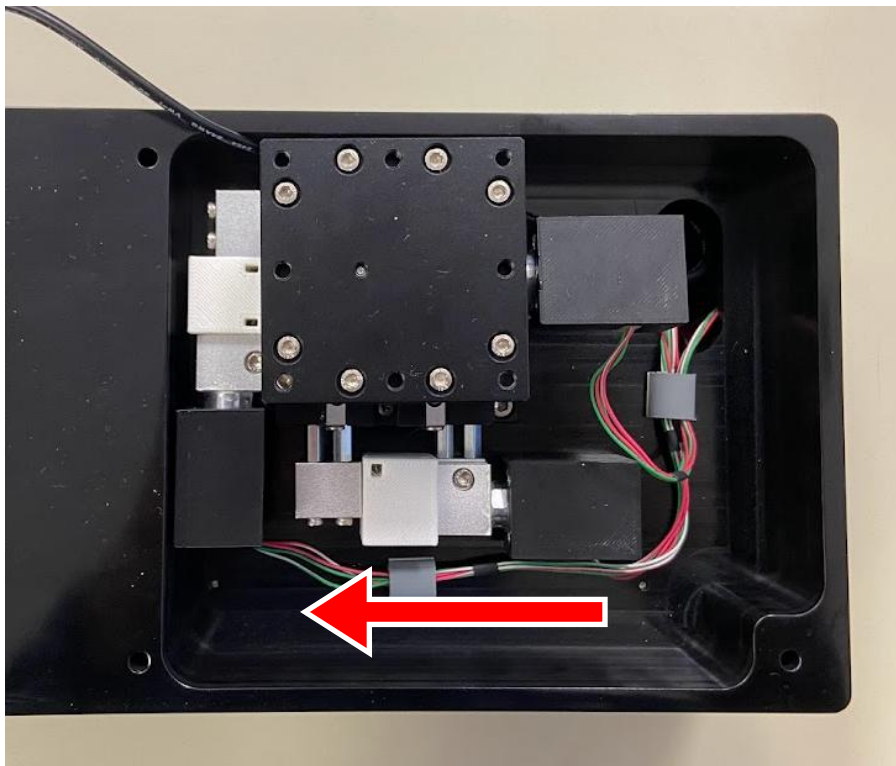

Unpackage the camera assembly and attach to camera mount with the included M3 fasteners.



The camera assembly can now be fastened on to the stages using a 3mm hex key.



The camera USB cable should now be attached and tightened down with the thumb screws.



Run USB cable through back hole of top cover. Start lowering the cover onto the camera assembly with the ring LED connector placed through the front hole of cover.



Next attach the camera cover using the long 3mm hex key provided fasten the 3 x M4 cover fasteners located below.

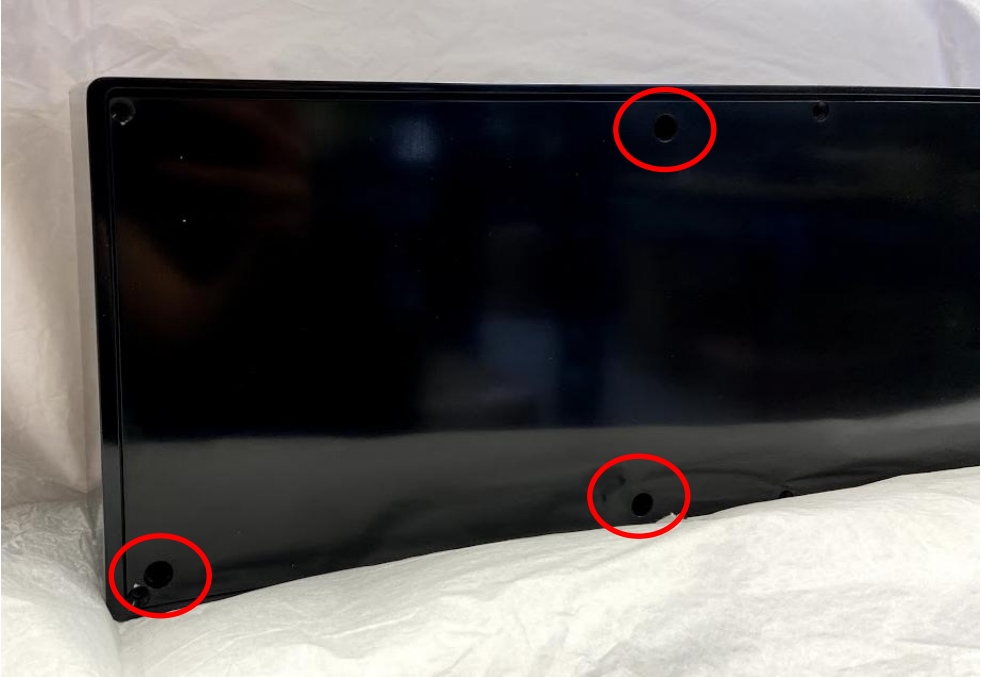

Remove Lens Cap and Mount the Ring Light on the Lens Assembly

Remove the lens cap from the lens assembly. Attach the ring light to the end of the lens assembly using the 3 set screws spaced around the ring light.



Set Test Chamber on the Chamber Holder

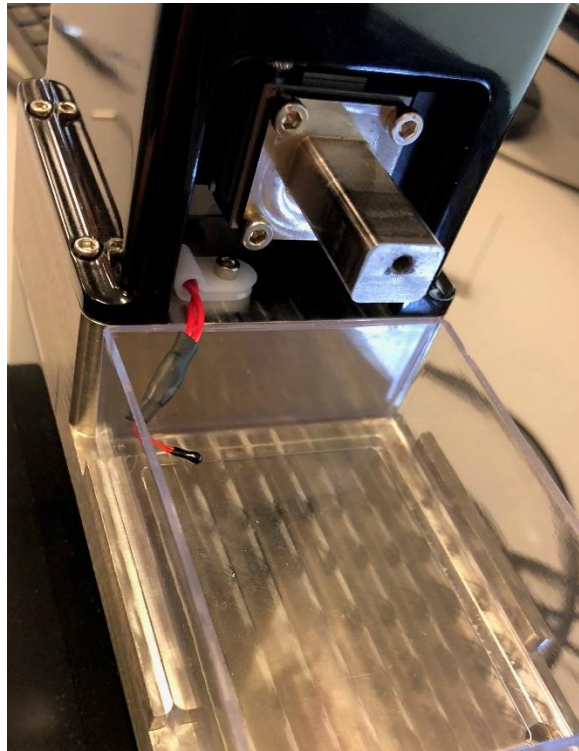

Set the fluid bath (test chamber) in the chamber holder on the main unit. This chamber is pre-assembled with a glass slide and gasket. Replacements are provided for these components.

Place Temperature Sensor in the Test Chamber

Bend the temperature sensor into the test chamber. This chamber can be filled with fluid for which temperature control can be specified. The temperature sensor functions best when it is fully immersed in fluid and is not touching the side of the chamber.

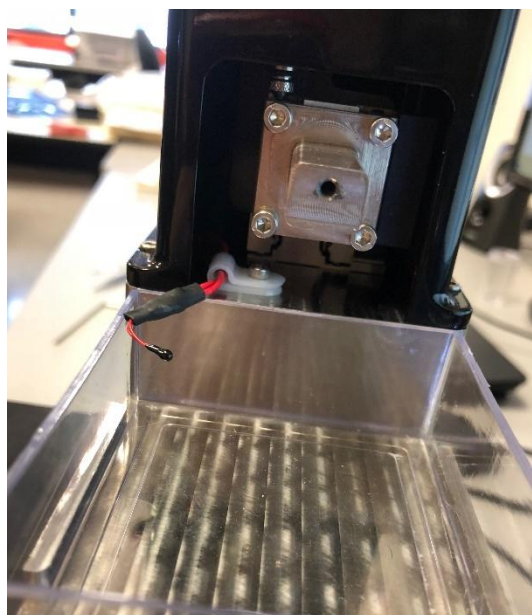

Connect Cables

Few power and communication cables need to be connected between the main unit, a power supply, and a computer:

- 20V power supply to power input jack on the main unit
- LED ring light to control box power extension
- USB Cable to back of camera (do not yet connect to PC)
- USB Cable for the main system (next to power supply jack)

NOTE: At the completion of this step, there should be 2 USB connections ready to connect to the PC USB ports

- Black USB cable from camera (this will require a USB 3.0 port)
- Black USB cable from the main system



Camera USB

Remember to tighten camera USB connection by rotating the 2 pin fasteners on the cable.

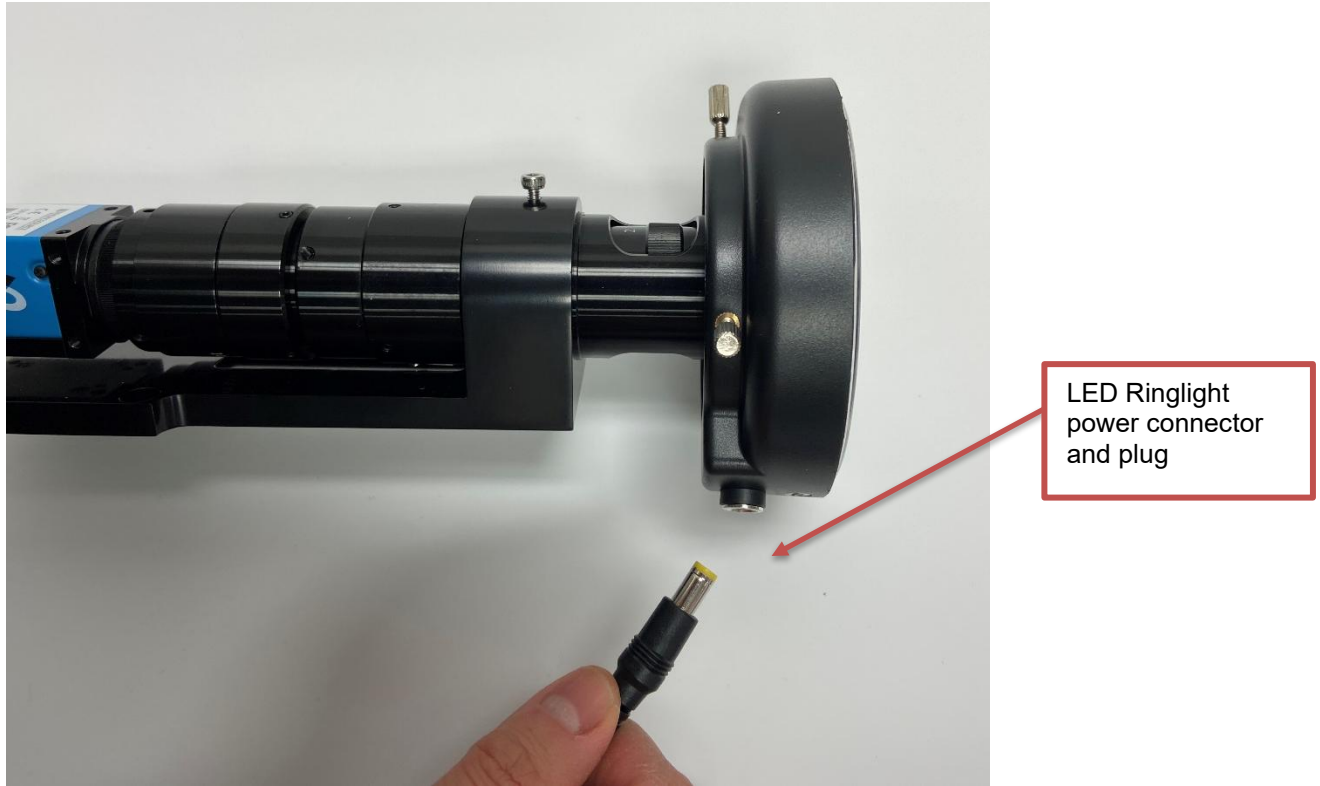

System Calibration Check

After the MicroTester G2 is fully assembled and set up, the MicroTester G2 software must be installed (see Appendix B). The system can then be switched on and the computer connectivity may be tested by opening an initial test. However, before any tests are run, it is recommended to check the piezo and optics calibrations. Instructions for these operations can be found in Section 8: System Calibration and Advanced Tools.

12. Appendix B: Software Installation

1. Download the software installation package from the provided link and save to a known location
2. After this is complete, go to the uncompressed installation folder and select *MicroTester Installer.exe*. Details of typical dialogue boxes are shown below.
3. Follow the prompts as shown on the next few pages.
4. Once the installer is finished, plug the USB cables into a USB port for the following components:
 - Camera (black USB cable)
 - Position Sensor, Piezo Actuator Controller, and Arduino DUE USB hub cable

The MicroTester G2 requires at least 2 USB ports for operation.

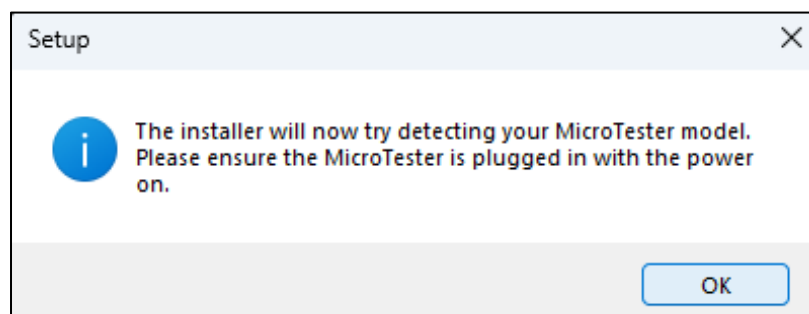
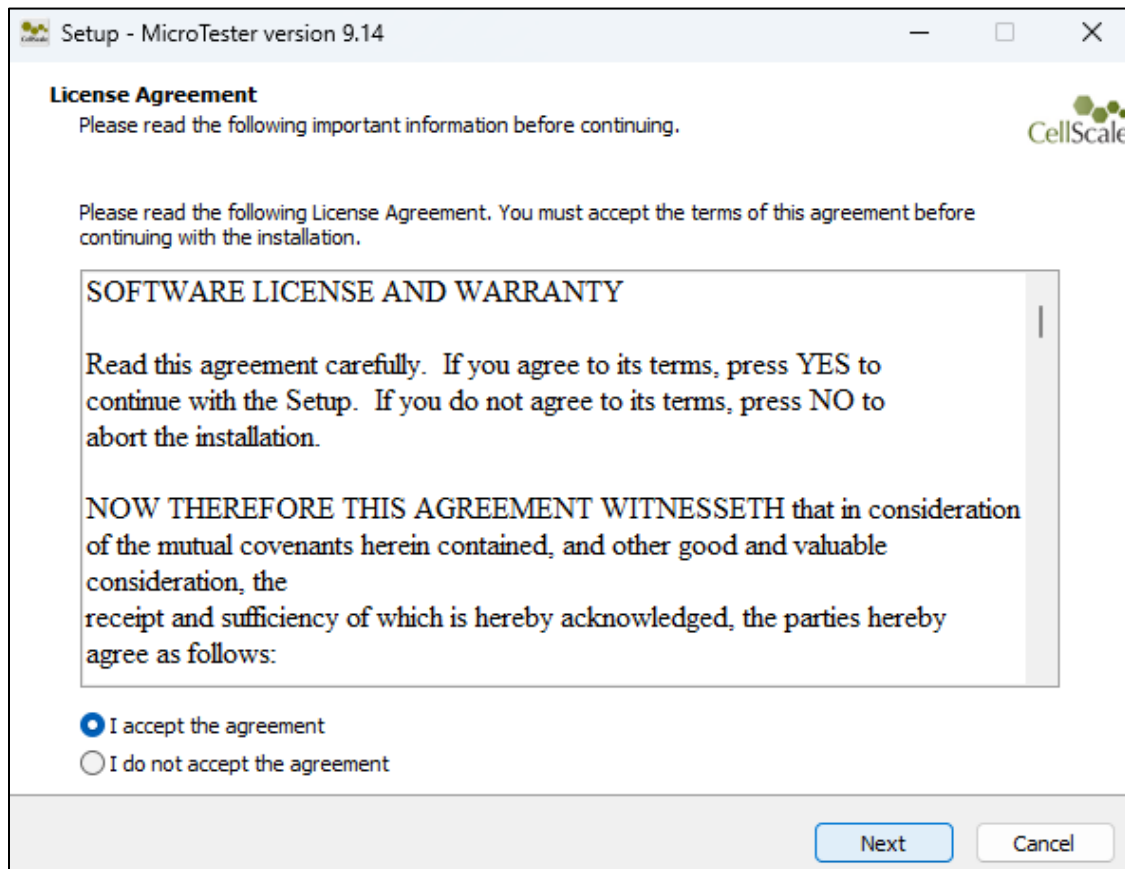

If your MicroTester is detected this screen will popup:

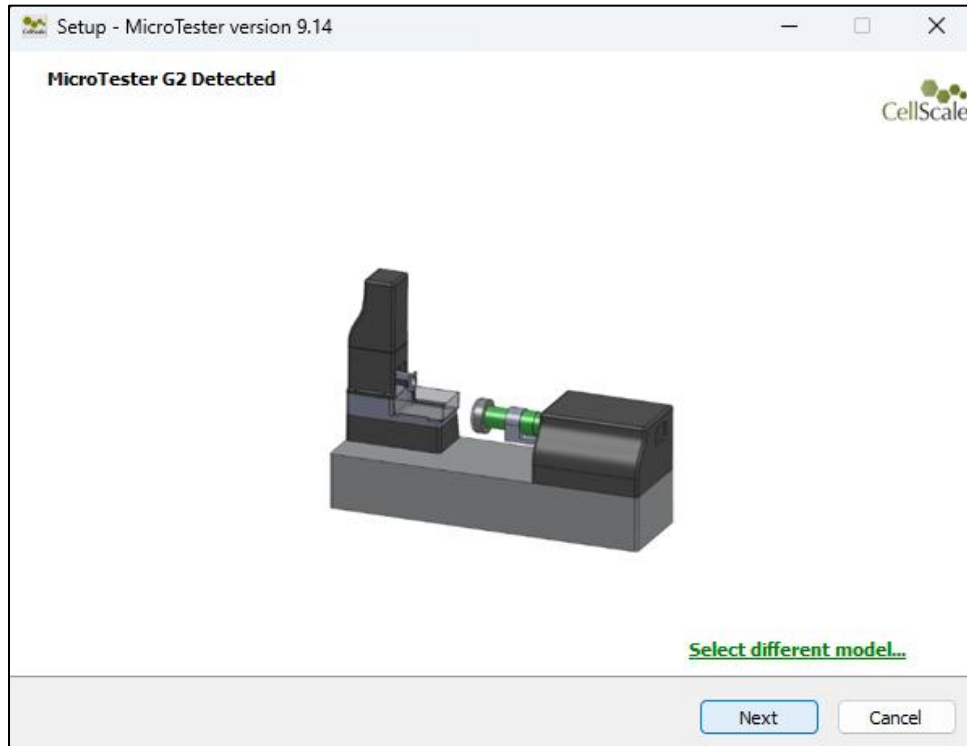

If MicroTester is not detected, then you will be taken to a model selection screen where you can select your MicroTester model. To install the correct user manual and templates please select the appropriate model.

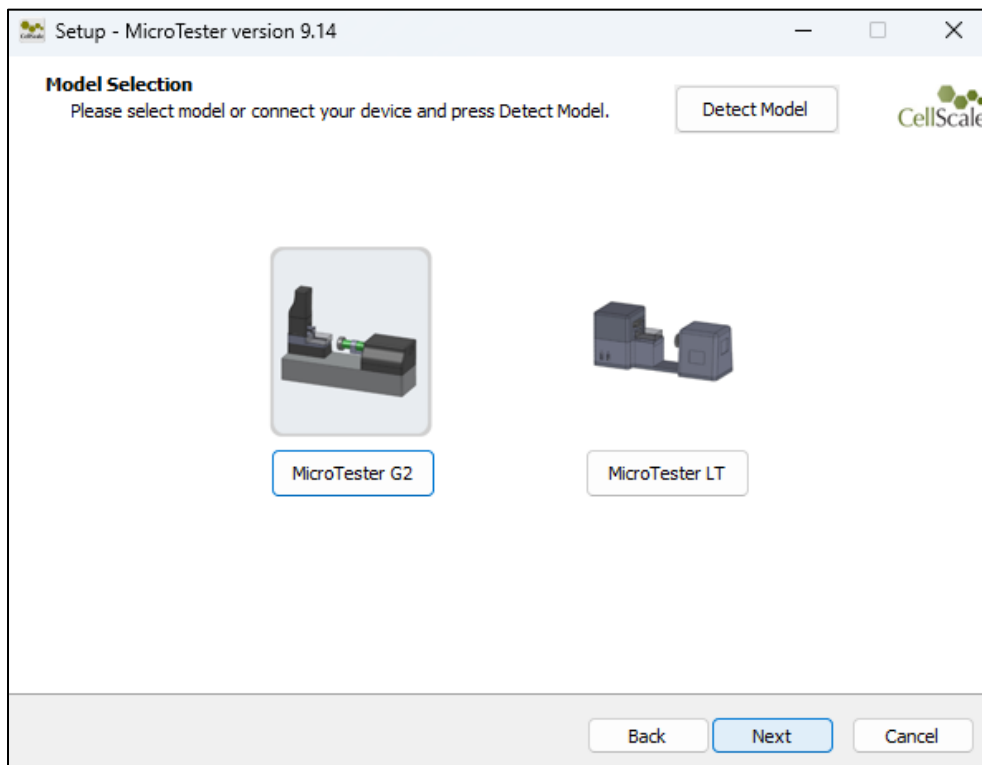

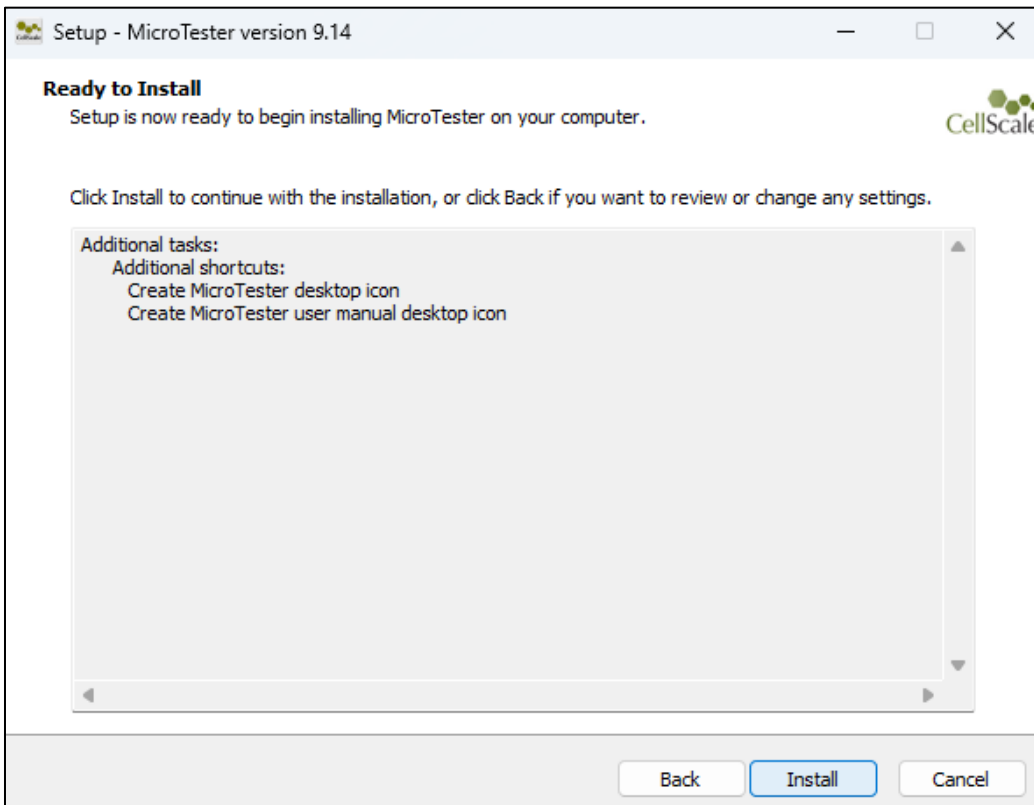
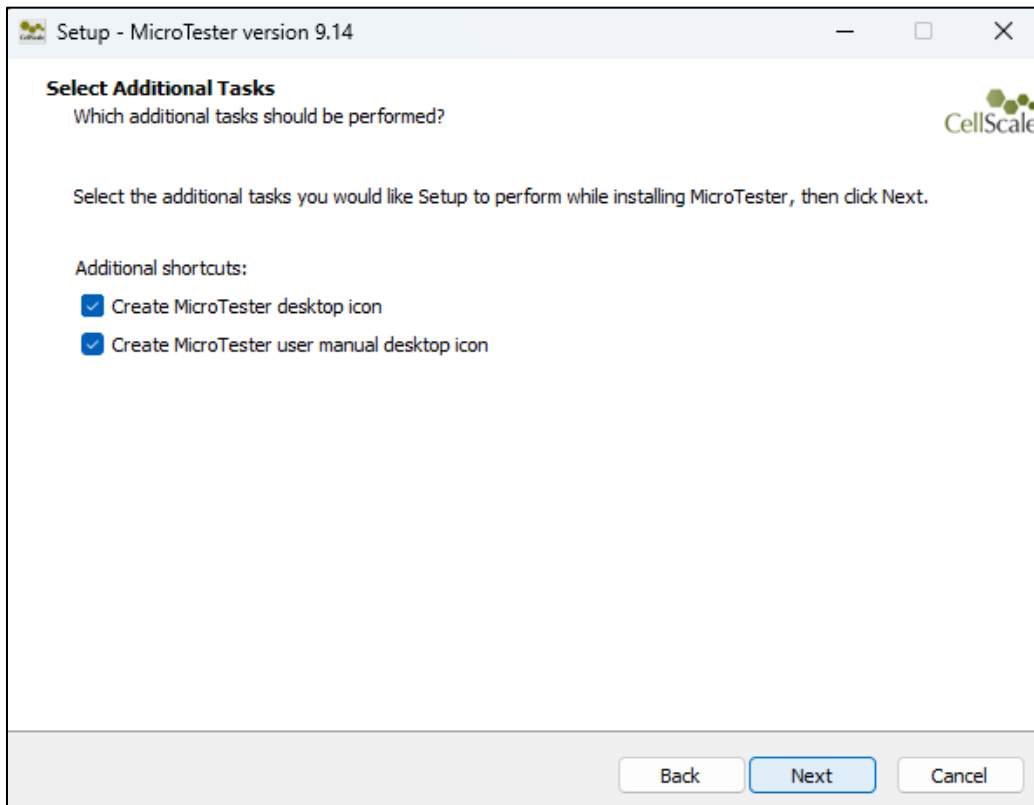

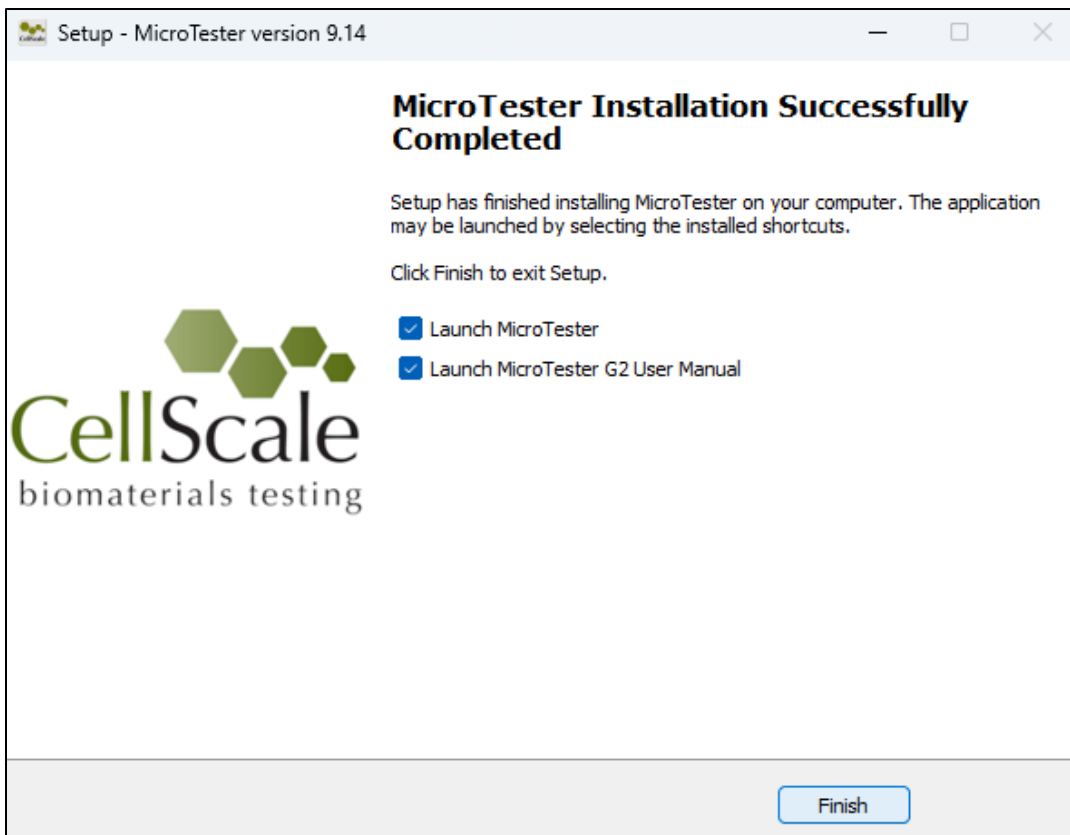
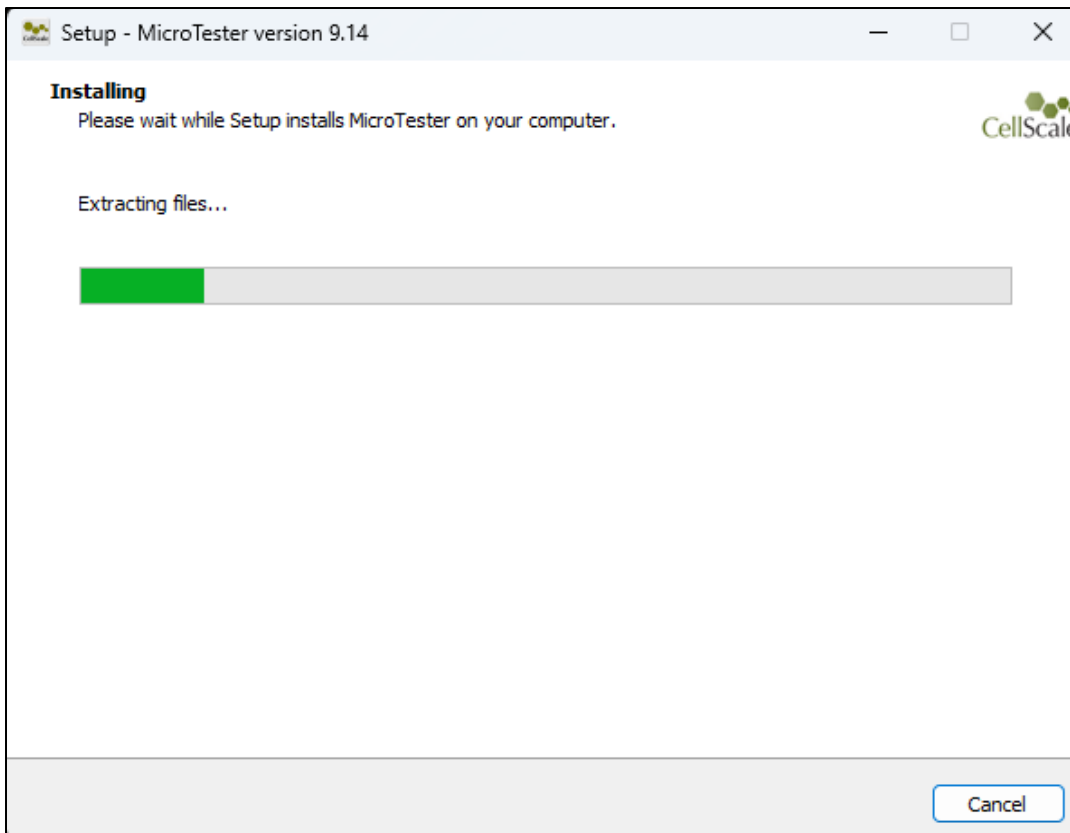

Update Firmware

Periodic firmware updates may be issued by CellScale for the MicroTester. When a new firmware or software is available, you may download it from our website (www.cellscale.com/downloads).

To update the firmware:

1. Connect the MicroTester to the PC via USB and turn on power to the MicroTester
2. Open the UpdateFirmware.exe program located in MicroTester>Software>Utilities>Update Firmware
3. The program will automatically update the firmware of the MicroTester
4. Power cycle the system after the firmware is successfully updated before using the MicroTester software again

The firmware version is checked and the automatic updater is also run when installing a new version of the software.

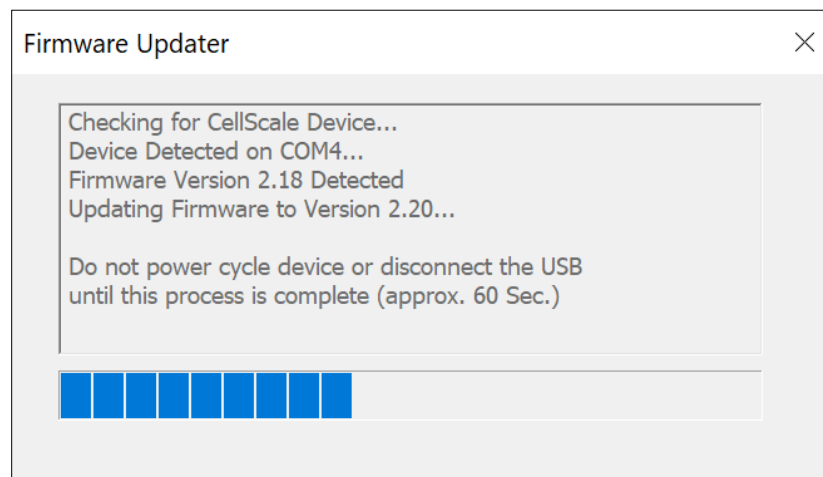

If the automatic firmware update software does not work, please follow the manual steps below:

1. With the MicroTester connected to the PC and turned on, launch the manual firmware update software located in *MicroTester>Utilities>Update Firmware>Advanced*.
2. Click the *Connect* button.
3. Load the firmware file using the *Browse* button. The file will be a .bin extension.
4. Execute the update using the *Update* button.
5. Power cycle the system after the firmware is successfully updated before using the MicroTester software again.

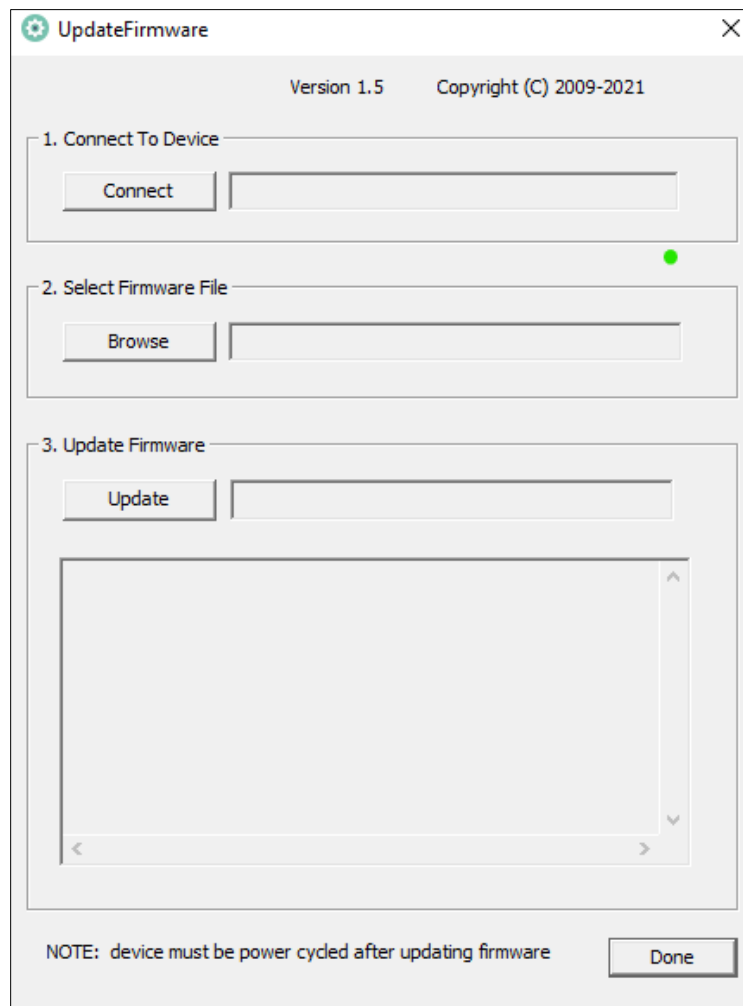

13. Appendix C: Shear Testing



Some MicroTester G2 systems are equipped with an additional displacement sensor to measure horizontal displacement of the microbeam during a test so that tests can be executed in this axis. This allows a type of shear testing to be performed on samples.

Installing the Shear Axis Keyence Sensor

1. Unbox the Keyence sensor from its box, it should have a collar and nut installed on the measuring end. This item is very sensitive, use caution when handling



2. Next, remove the nut from the collar



3. Carefully slide the Keyence probe into the shear axis mounting bracket, when doing this slide the nut on and finger tighten it in place.

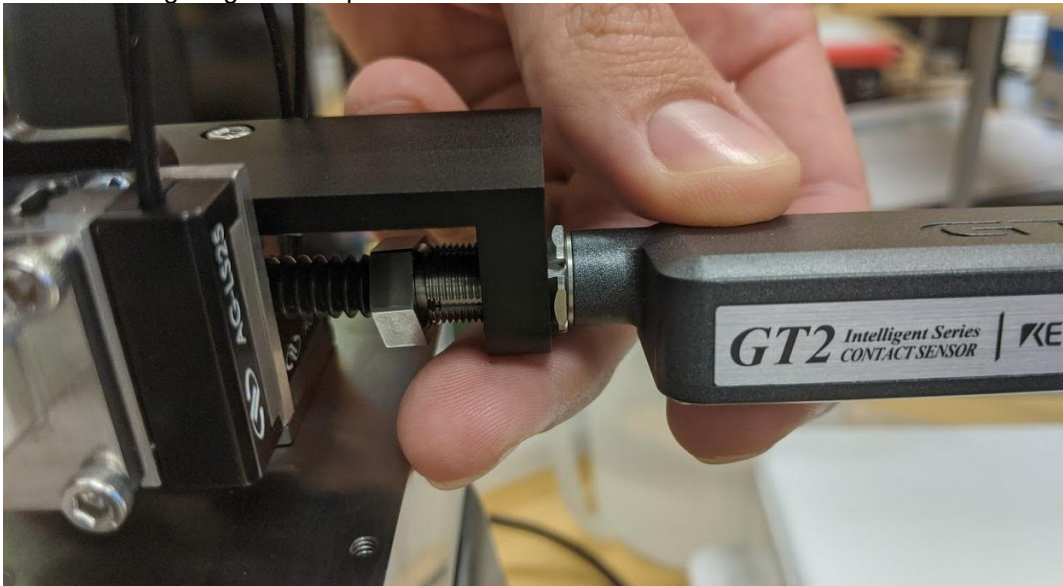

4. Using supplied wrench tighten the nut to hold Keyence sensor in place. Be aware you do not want to overtighten this nut as it can damage the sensor.

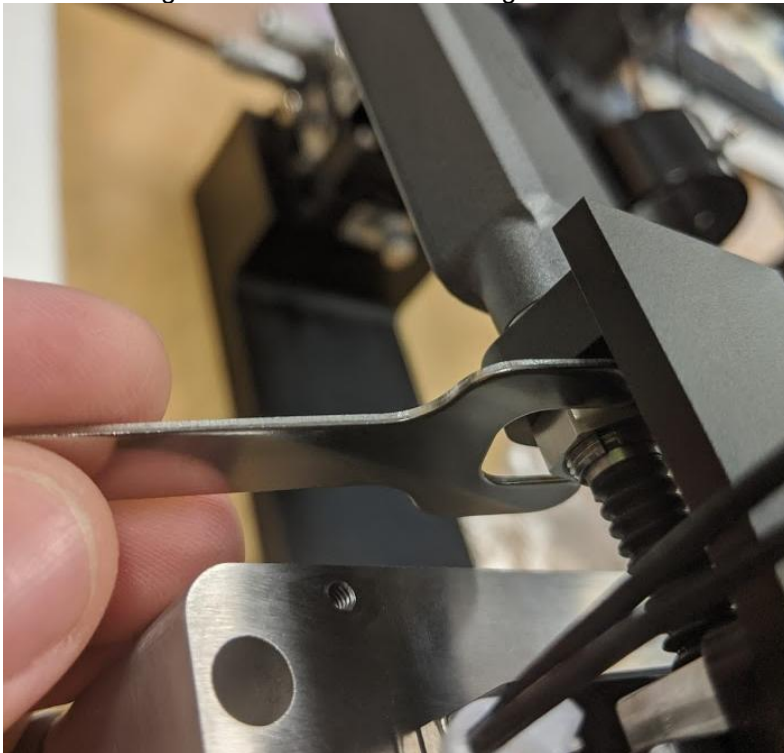

5. Next, insert cable into the back end of the sensor and install cover to complete installation

On systems equipped for shear testing, a special version of the software is provided directly to the user (the link on the CellScale website contains the single-axis version of the software). In the "Set Parameter Editor", this allows X-Shear to be selected as the Control Axis. Compression and Shear movements can be executed in the same test sequence by selected a different Control Axis for different test sets. For shear testing, positive magnitudes are to the right.

Set Parameter Editor

Name (Example: "Squish1", "TestData1")

Axis

Control Axis

Control Mode

Control Function

Shear Magnitude

Tolerance (um)

Correct Overshoot

Cycle

Loading Duration (S) Do Not Load Repetitions

Hold Duration (S) Data Output Frequency (Hz)

Recovery Duration (S) Do Not Recover Image Output Frequency (Hz)

Rest Duration

OK Cancel

Additional data columns for the X-Shear axis are output in the data .csv file for these specially equipped systems. In addition, the live graphs during a test will contain additional data output for this axis.

- □ ×

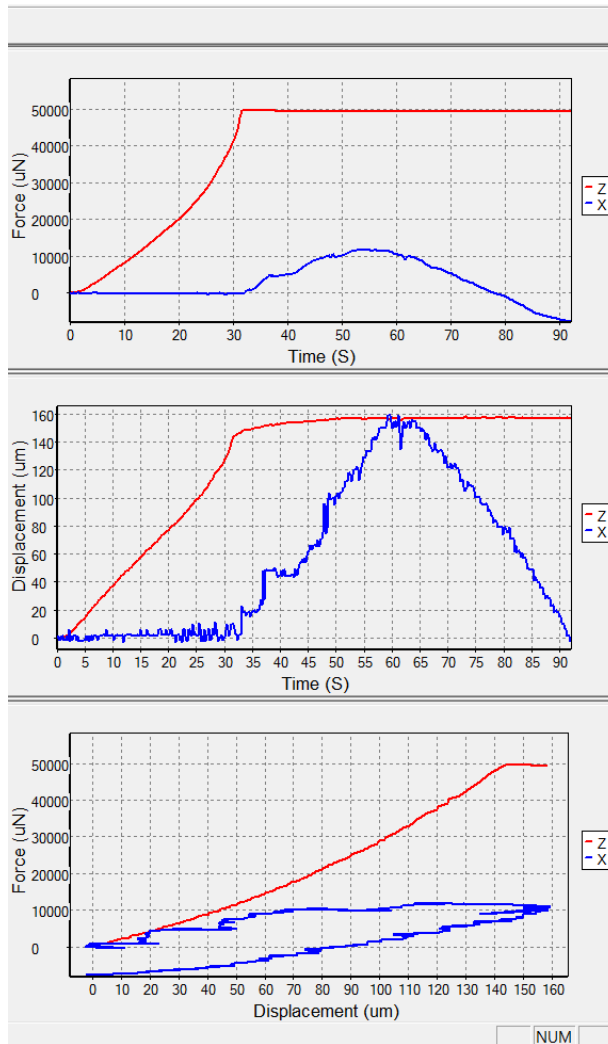

Also, the image tracking settings will typically differ from that of a single axis MicroTester G2 system. The tracking template and search region settings can be found in Advanced in the Settings menu. This will be preset as a square dialog box under the demo template provided so that image tracking can be performed equally well in both axes. If single axis testing is being performed, these settings can be altered so that the template and search region is optimized for the axis being used.

Advanced Settings

Hold Phase Control

Limit Moves To a Maximum of 50 Steps Per 200 mS

Limiting moves may cause target values to be reached more slowly
But can be set to ensure that each move completes within each 200 mS
Allowing for full 5Hz data output with no skipped points

0.75 Slow Ratio

Corrections for overshoot or undershoot are multiplied by the Slow Ratio
If this ratio is small target values may be achieved slowly
If this ratio is large oscillations about the target value may occur

Image Tracking Settings

Search Region Minimum (+/- pixels) 3 x 8

Template Region Size (+/- pixels) 12 x 12

Increasing these settings will increase real time computations during data
And may result in 5Hz cycle time not being achieved.

OK Cancel

14. Appendix D: Camera Lens Attachment

The MicroTester G2 system features a camera lens tube with an operating detent mechanism. This prevents accidental slippage during experimentation, giving a consistent and crisp focus view of the intended target. The standard MicroTester G2 comes with an already-attached camera assembly. This standard assembly includes the camera bracket (short), camera, objective tube (1x), and auxiliary lens (1x). The standard assembly is depicted below.



The standard MicroTester G2 also comes with the 2x camera objective tube, 2x mounting bracket, and 2x auxiliary lens for different applications seen below. Changing either the objective tube OR the auxiliary lens will have the effect of doubling the magnification. Change BOTH will have the effect of increasing the magnification by a factor of 4.





In order to replace the auxiliary lens, slowly rotate the attached piece counter clockwise. Be careful not to touch any exposed lens. Attach the wanted auxiliary lens by slowly rotating the part clockwise onto the camera lens tube until a snug fit is apparent. Changing the auxiliary lens will change the working distance of the optics and thus require changing the mounting bracket.



In order to replace the objective tube, first loosen the 2 set screws (circled in red) from the camera bracket and take off camera assembly from MicroTester G2 device.



Remove the camera from the objective tube by slowly rotating (counter clockwise) the camera.



To change between 1x and 2x objective tubes:

1. Locate ring B which only has 2 screws and loosen them
 - a. **Do not loosen screws on ring A and C!**

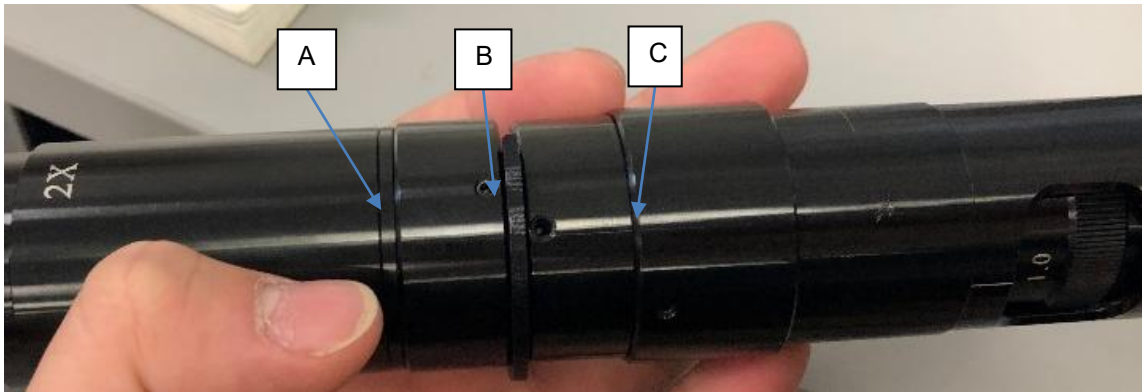

2. Gently pull the tube assembly out and replace it with the desired tube



- a. Ensure the new tube is pushed up against the side of ring A

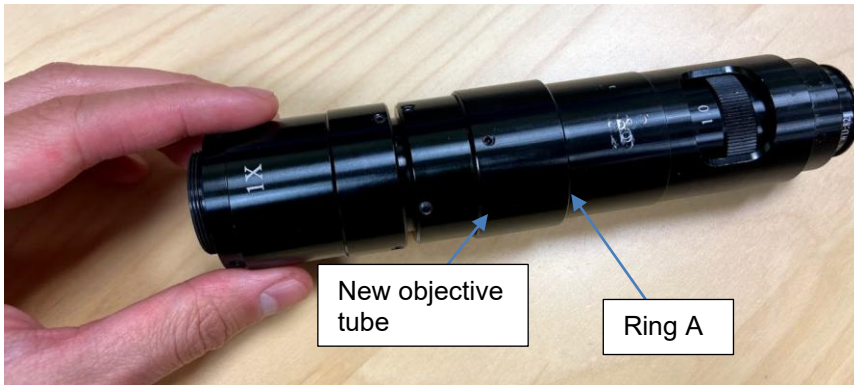

3. Tighten both screws at B
4. Screw the lens assembly back onto the camera
5. Place the assembly into the appropriate bracket and tighten the set screws to hold it in place
 - a. Use the longer bracket when using the 2x objective tube, and the shorter bracket with the 1x tube

Take camera system and line detent clip with the horizontal set screw. Carefully push camera system back into the intended bracket. The short bracket is meant for the 1x auxiliary lens while the longer bracket is for the 2x auxiliary lens. Rotate camera system counter-clockwise until detent clip is facing downwards. Tighten set screws.



15. Appendix E: Attaching Secondary Camera

An additional option for the MicroTester G2 is a secondary camera axis that allows you to view your sample from the side. This option includes an anodized aluminum bracket what mounts to the side of the device. This bracket is help on by 4x M4x12 fasteners.

To attach this bracket the bottom cover must first be removed, this is done by carefully laying the system on its side. It is recommended to support the piezo motor cover with a piece of foam or something soft, so you do not scratch the surface. Once the system is on its side remove 6 M3x6 flat head fasteners using the provided 2mm hex key

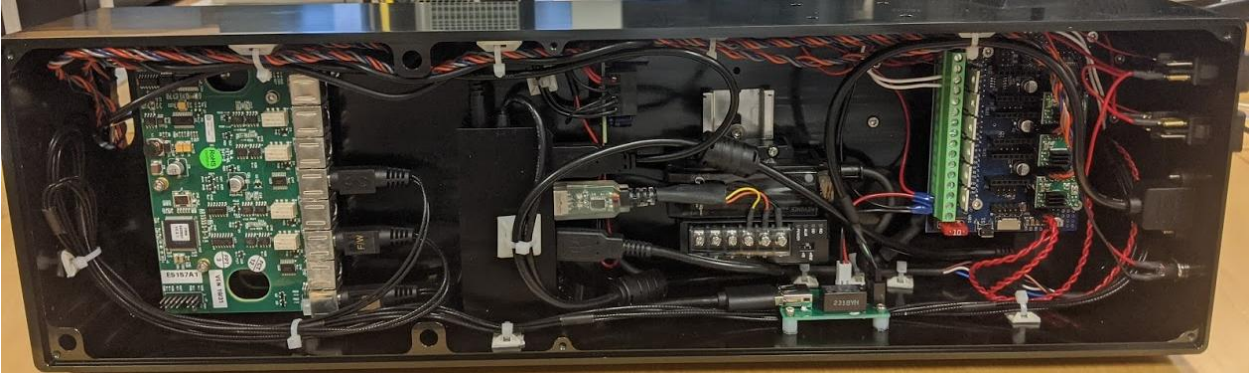

The bracket will attach to the 4 holes shown below.



When the system is on its side set the bracket in place and fasten it with provided fasteners.

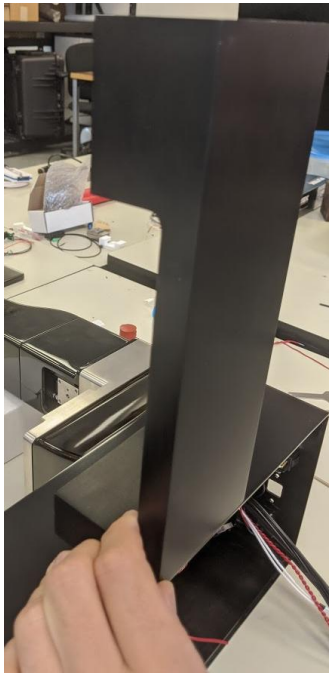

Attach the Up/Down stage to the remainder of the XYZ stage with the supplied M4 fasteners. See the images below for proper orientation.

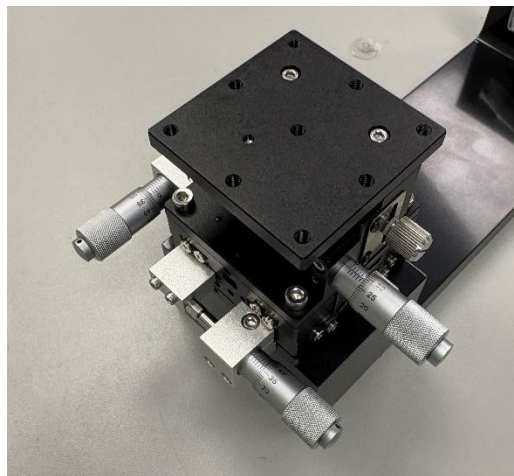
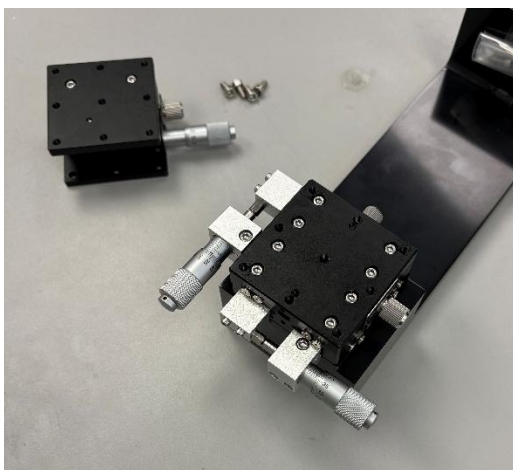

Attach the camera bracket to the top of the XYZ stage using the supplied M4 fasteners.

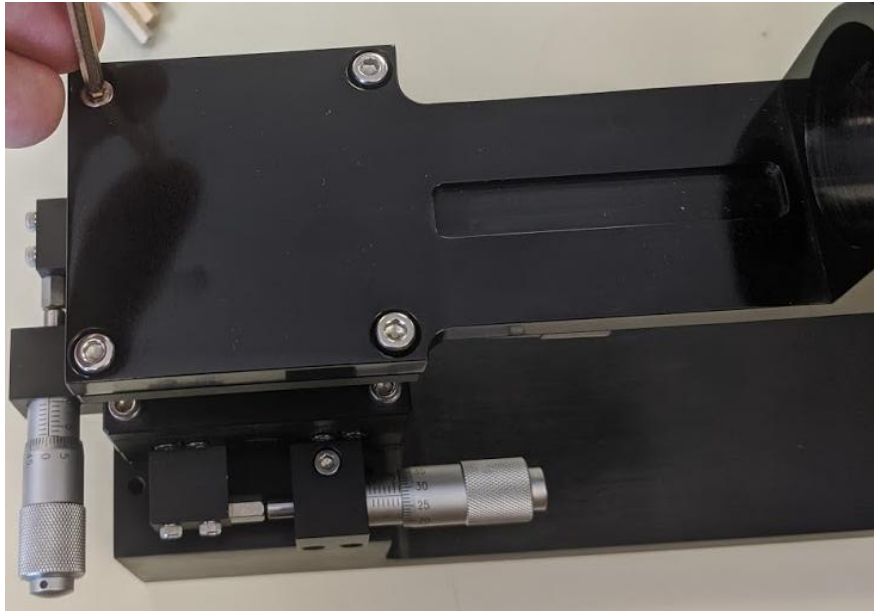

Attach the camera lens to the camera and slide it through the camera bracket. Secure it in place by tightening the M3x8 set screws with a 2.5mm hex key.

Secure the secondary ring light over the lens.



Connect the USB cable to the camera and plug it into a USB 3.0 port on your computer.

To utilize the secondary camera feature, start a new test with the 'demo2Camera' template provided with the MicroTester software. You may edit this template as needed to suit your sample and testing requirements. Remember to save your changes by using the 'Save as a new Template' under the 'File' drop down menu.

Create Test From Template

Select

demo2Camera

Test Name

Test_001

Data Directory

C:\CellScale\MicroTester\Data

Browse

Template Directory

E:\Dropbox (CellScale)\Manufacturing Info\MicroSquisher\'

Browse

OK

Cancel

If you are running a test near the edge of the media dish, it may be difficult to focus the secondary camera due to the radius of the corner on the plastic dish. We recommend sliding the dish forward slightly or placing your sample further back to allow the secondary camera to focus on your specimen.

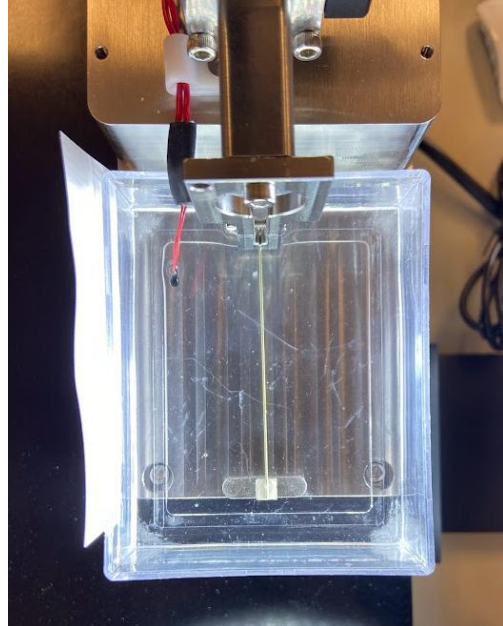

Depending on where your MicroTester is set up, it may be helpful to place a small piece of white paper along the left edge of the dish (when looking at the beam head on). This will eliminate any background objects from being captured and help with reflecting light towards the camera.

To calibrate the secondary camera, go to Tools>Calibrations>Aux. Optics Calibration. Repeat the Optics Calibration procedure for the secondary camera (see section 8. System Calibration and Advanced Tools).

Auxiliary Camera Optics Calibration

1. Position the Crosshairs on the Calibration Target

2. Enter the Distance Between the Crosshairs (um)

1000

4. Pixels Per um

Calculate Pix/um Delete Row(s)

Pix/um	

Previous: 2.1027 0 Average Value

Apply Cancel

When two cameras are in use with the MicroTester, a second initial size field will be displayed in the software. To adjust the initial size, move the crosshairs in the live display of the second camera.

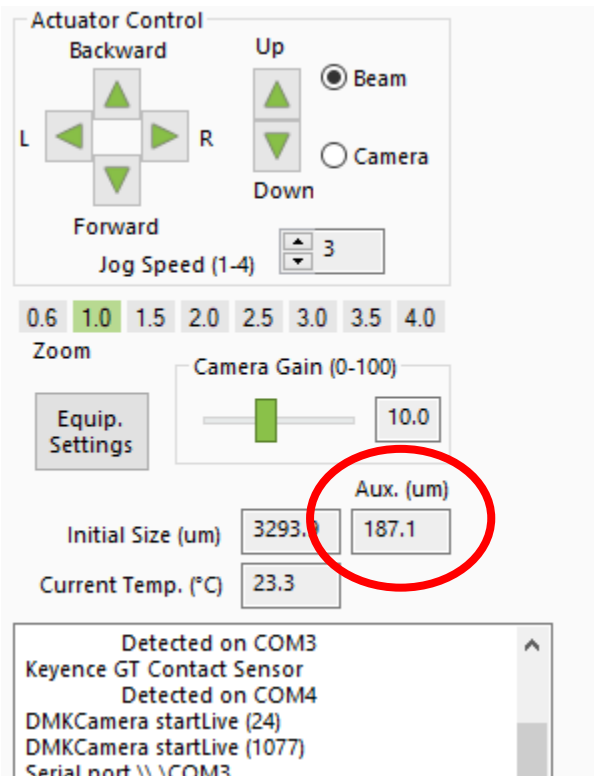

16. Appendix F: Software Troubleshooting

This software is recommended for use with a Windows 10 operating system. Use on Windows 7 systems may result in some hardware communication errors with the MicroTester, such as the following:

Issue: MicroTester software cannot communicate with camera and/or controller

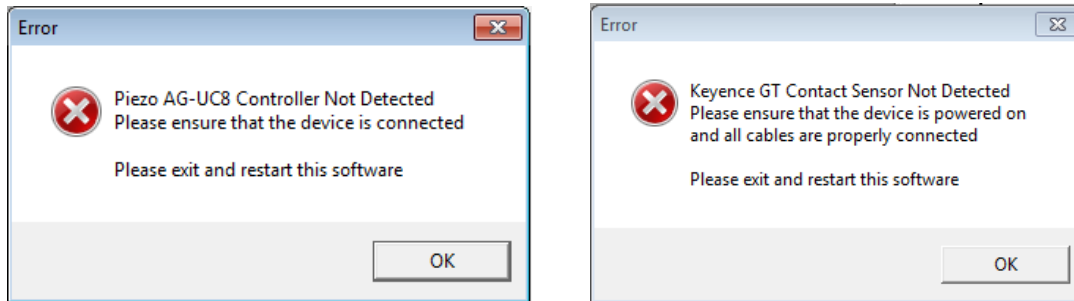

Solution: This is often caused by turning off the device while the software is still running on Windows 7, then trying to reopen the software. If you encounter this error, try closing and turning everything off, removing and reinserting the USBs, then try again. Make sure both USBs and the power supply are plugged in and the device is on before you launch the software. You can also try manually renumbering the port numbers for the USB port being used by the MicroTester controller in your computers Device Manager > Ports. Finally, try restarting your computer.

17. Appendix G: Accessories

The MicroTester has different accessories to conduct testing on your samples. We will utilize the first 5 steps from Section 9. Mounting a MicroBeam. After completing the steps, your beam should look like the following:

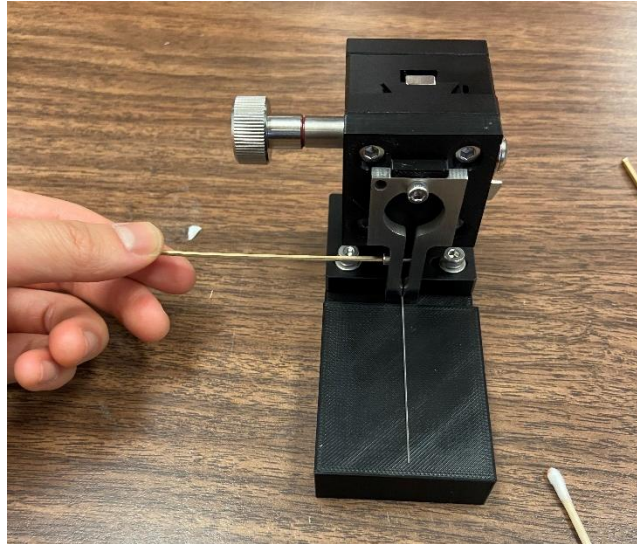

Once you have your beam to at this stage, follow the following steps depending on the accessory. The general protocol on the setup of each accessory is outlined but this might vary depending on your specific application.

Tension Forks

1. Place the desired tension fork below the tip of the microbeam. Use tweezers to align the tension fork and ensure the tip of the microbeam is in line with the edge of the fork. Ensure that the tension fork is not at an angle.

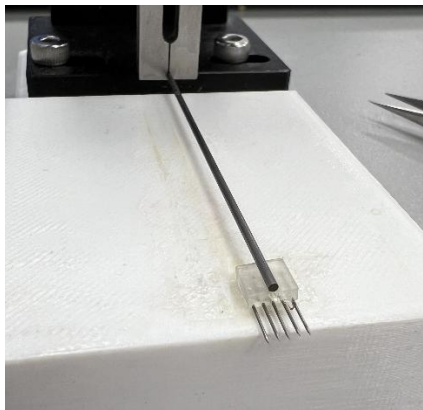

2. Apply a dab of glue using the cotton swab and then cure the glue by brushing a small amount of glue accelerator.



3. Lift the stage and remove the clamp using a 2.5mm hex key. Attach the clamp to the MicroTester system.
4. Take the bottom tension fork and attach your sample carefully using tweezers.

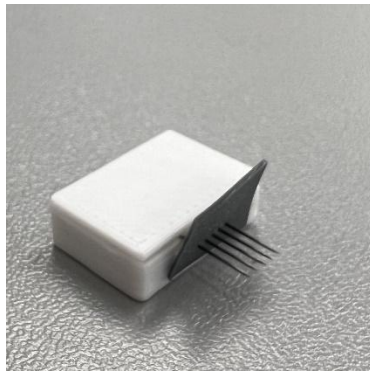

5. Place this in the media bath. Slide the bath away from the upper tension fork. Make sure both sets of forks are facing the camera.



6. Using tweezers and moving the bath back, puncture the sample with the upper fork.



3-Point Bend

1. Gather the specific sized U-Channel (3mm or 5mm spacing) and place it in the bath.



2. Place your sample on top of the U-Channel. You may use some type of adhesive to ensure that the sample does not move.

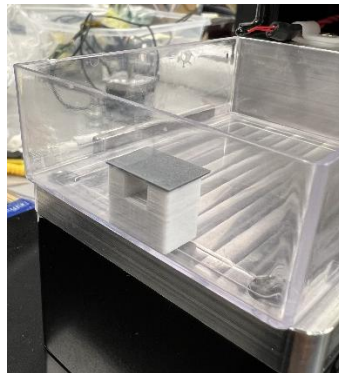

3. Place the second U-Channel on top of the sample.



4. Install the microbeam without any fixtures on the end. Note: The bath will need to be moved forward slightly.

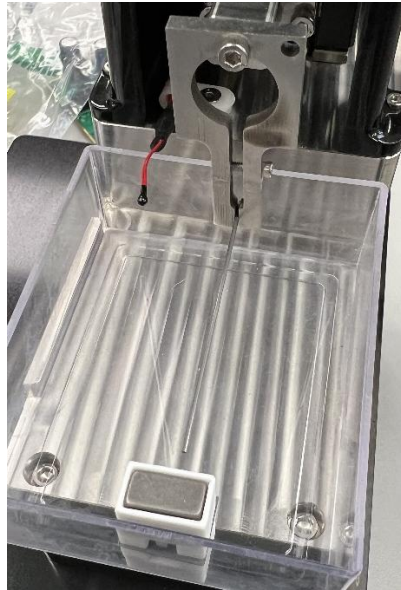

5. Align the beam to be within the U-Channel and above the sample. Remember to push the bath back to its original position.

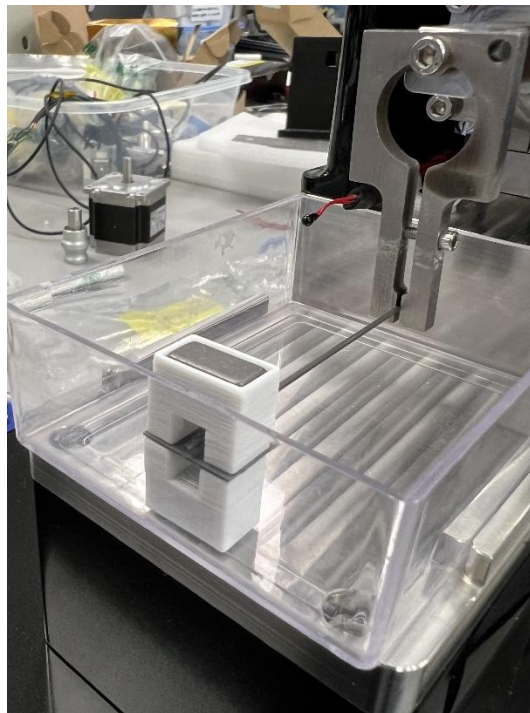

Spherical Indentation

1. Place the desired spherical indenter below the tip of the microbeam. Use tweezers to ensure the tip of the microbeam is centered with the indenter. You may also create an indentation in the vertical stage to limit the indenters' movement.

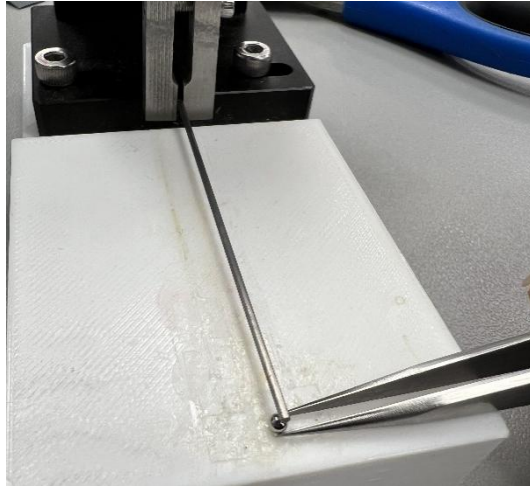

2. Apply a small dap of glue from the tip of the cotton swab while holding the indenter with the tweezers. Cure the glue by brushing a small amount of glue accelerator.

